

HumeCeptor[®] system Technical manual

Issue 5



Contents

HumeCeptor® system	1
System operation	3
Bypass chamber	3
Treatment chamber	4
Independent verification testing	4
System options	8
Variants	8
Design information	13
Configuration of the stormwater system	13
Location in the stormwater system	13
Catchment area	13
Sizing HumeCeptor® systems	13
MUSIC/pollutant export model inputs	15
System installation	16
System maintenance	17
FAQs	17
References	18
Appendix	19
Precast solutions	32
Contact information	33

HumeCeptor® system

The HumeCeptor® system is a patented hydrodynamic separator, specifically designed to remove hydrocarbons and suspended solids from stormwater runoff, preventing oil spills and minimising non-point source pollution entering downstream waterways.

The HumeCeptor® system is an underground, precast concrete stormwater treatment solution that utilises hydrodynamic and gravitational separation to efficiently remove Total Suspended Solids (TSS) and entrained hydrocarbons from runoff. First designed as an 'at source' solution for constrained, commercial and industrial sites it has been improved and expanded to service large catchments, mine and quarry sites, inundated drainage systems, and capture large volume emergency spill events. The system is ideal for hardstands/wash bays, car parks, shopping centres, industrial/commercial warehouses, petrol stations, airports, major road infrastructure applications, quarries, mine sites and production facilities.

Independently tested, and installed in over 30,000 projects worldwide, the HumeCeptor® system provides effective, and reliable secondary treatment of stormwater for constrained sites.

- **The system reliably removes a high level of TSS and hydrocarbons**

The HumeCeptor® system was developed specifically to remove fine suspended solids and hydrocarbons from stormwater, and has been certified to achieve high pollutant removal efficiencies for TSS (>80%) and Total Nutrients (TN) (>30%) on an annual basis.

- **It captures and retains hydrocarbons and TSS down to 10 microns**

Each system is specifically designed to maintain low treatment chamber velocities to capture and retain TSS down to 10 microns. It also removes up to 98% of free oils from stormwater.

- **Each device is sized to achieve the necessary Water Quality Objectives (WQO) on an annual basis**

Utilising the latest build-up and wash-off algorithms, PCSWMM software for the HumeCeptor® system ensures that the device chosen achieves the desired WQO (e.g. 80% TSS removal) on an annual basis.

- **Its performance has been independently verified**

The HumeCeptor® system's technology has been assessed by independent verification authorities including the New Jersey Department of Environmental Protection (NJDEP), The Washington Department of Environment (USA), and by the Canadian Environmental Technology Verification program (ETV).

Right:
The bypass
chamber of a
HumeCeptor®
system

- **The system is proven**

The HumeCeptor® system was one of the first stormwater treatment devices introduced to Australia, and now after 30,000 installations worldwide, its popularity is testament to its performance, quality and value for money.

- **High flows won't scour captured sediment**

The unique design of HumeCeptor® units ensures that as flows increase and exceed the treatment flow, the velocity in the storage chamber decreases.

- **Nutrients are captured along with the sediment**

The effective capture of TSS results in the capture of particulate nutrients shown to be >30% of TN and Total Phosphorous (TP).

- **Fully trafficable to suit land use up to class G**

The HumeCeptor® system is a fully trafficable solution, it can be installed under pavements and hardstands to maximise above ground land use (loading up to class D as standard).

- **Custom designs allow for emergency oil spill storage, directional change, multiple pipes, tidal inundation and class G traffic loads**

A range of HumeCeptor® systems are available, built specifically to manage emergency spills (50,000 L storage), change of pipe directions, the joining of multiple pipes, high tail water levels as a result of tides or downstream water bodies, and high levels of hydrocarbons with auxiliary storage tanks.

- **We are experienced in the provision of world class treatment solutions**

Humes has a team of water specialists dedicated to the advancement of economical sustainable solutions, and the provision of expert advice and support.



System operation

The HumeCeptor® stormwater treatment system slows incoming stormwater to create a non-turbulent treatment environment, allowing free oils and debris to rise and sediment to settle. Each HumeCeptor® system maintains continuous positive treatment of TSS, regardless of flow rate, treating a wide range of particle sizes, as well as free oils, heavy metals and nutrients that attach to fine sediment.

The HumeCeptor® system's patented scour prevention technology ensures pollutants are captured and contained during all rainfall events.

Bypass chamber

1. Stormwater flows into the inlet (weir) area of the bypass chamber.
2. Design flows are diverted into the offline treatment chamber by a weir, orifice and drop pipe arrangement (refer to Figure 1).
3. The weir and orifice have been developed to create a vortex that sucks floating oils and sediment down into the treatment chamber.
4. During high flow conditions, stormwater in the bypass chamber overflows the weir and is conveyed to the stormwater outlet directly (refer to Figure 2).
5. Water which overflows the weir stabilises the head between the inlet drop pipe and outlet decant pipe ensuring that excessive flow is not forced into the treatment chamber, protecting against scour or re-suspension of settled material. The bypass is an integral part of the HumeCeptor® unit since other oil/grit separators have been found to scour during high flow conditions (Schueler and Shepp, 1993).

Figure 1 – HumeCeptor® system operation during design flow conditions



Figure 2 – HumeCeptor® system operation during high flow conditions

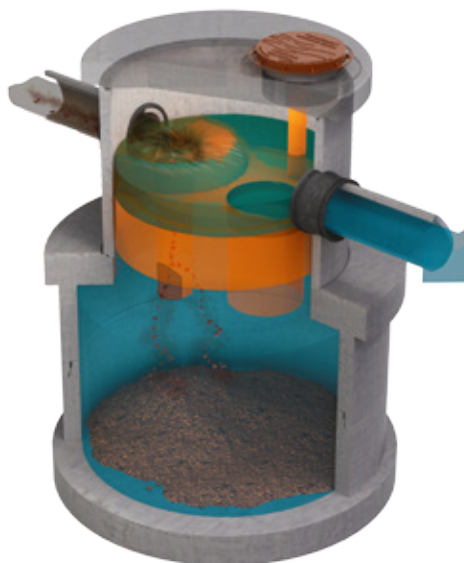

Treatment chamber

1. Once diverted into the treatment chamber through the weir and orifice, the drop pipe beneath the orifice is configured to discharge water tangentially around the treatment chamber wall.
2. Water flows through the treatment chamber to the decant pipe which is submerged similar to the drop pipe.
3. Hydrocarbons and other entrained substances with a specific gravity less than water will rise in the treatment chamber and become trapped beneath the fibreglass insert since the decant pipe is submerged.
4. Sediment will settle to the bottom of the chamber by gravity forces. The large volume of the treatment chamber assists in preventing high velocities and promoting settling.
5. Water flows up through the decant pipe based on the head differential at the inlet weir, and is discharged back into the bypass chamber downstream of the weir.

Independent verification testing

HumeCeptor® systems have been extensively researched by more than 15 independent authorities to validate its performance; it has now gained Environmental Technology Verification (ETV) certificates from ETV Canada, New Jersey Department of Environmental Protection (NJDEP) and Washington Department of Environment (WDOE).

A number of agencies have conducted independent studies; their results from these studies (over 100 test events) have been summarised in Table 1 below.

Table 1 – HumeCeptor® system performance summary

Pollutant	Average removal efficiency	Details
TSS	80%	Laboratory and field results, stable, hardstand, roads, commercial and industrial sites
TN	37%	Field results
TP	53%	Field results
Chromium	44%	Field results
Copper	29%	Field results
TPH	65%	<10 ppm inflow concentration
	95%	10 ppm - 50 ppm inflow concentration (typical stormwater)
	99%	>500 ppm inflow concentration (emergency spills)

Figure 3 – HumeCeptor® system field performance results for Total Suspended Solids (TSS) removal

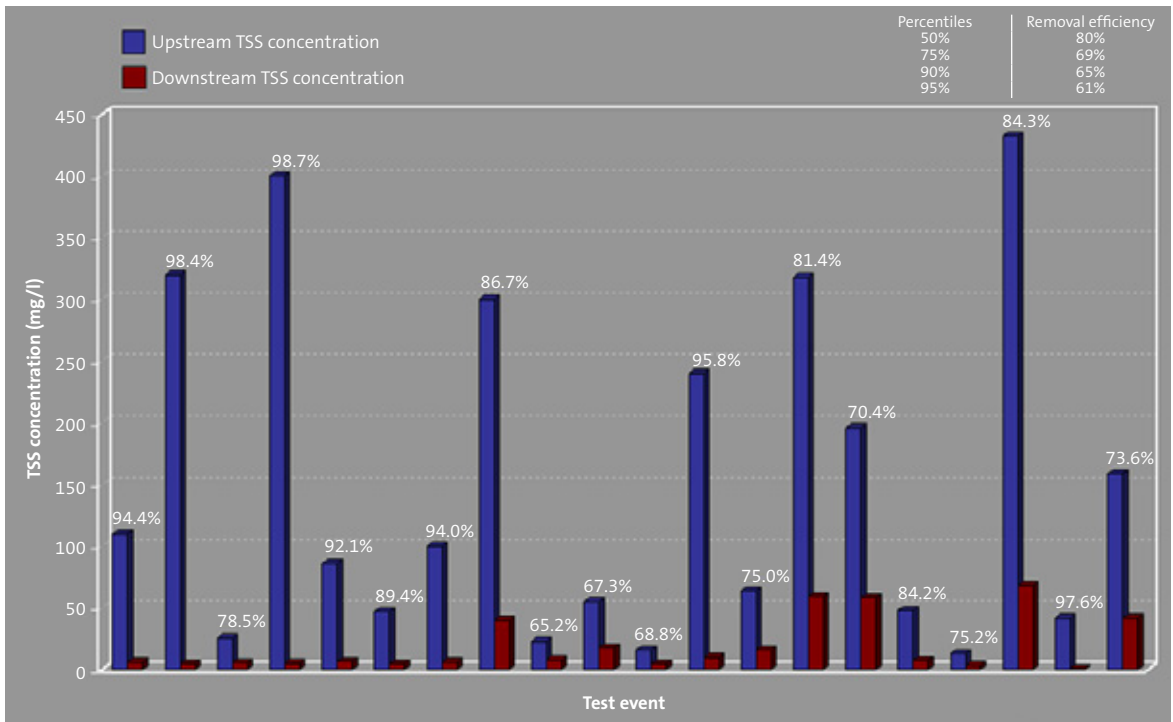

Note: Percentage values represent removal efficiencies

Figure 4 – HumeCeptor® system field performance for Total Petroleum Hydrocarbon (TPH) removal (influent concentration <10 ppm)

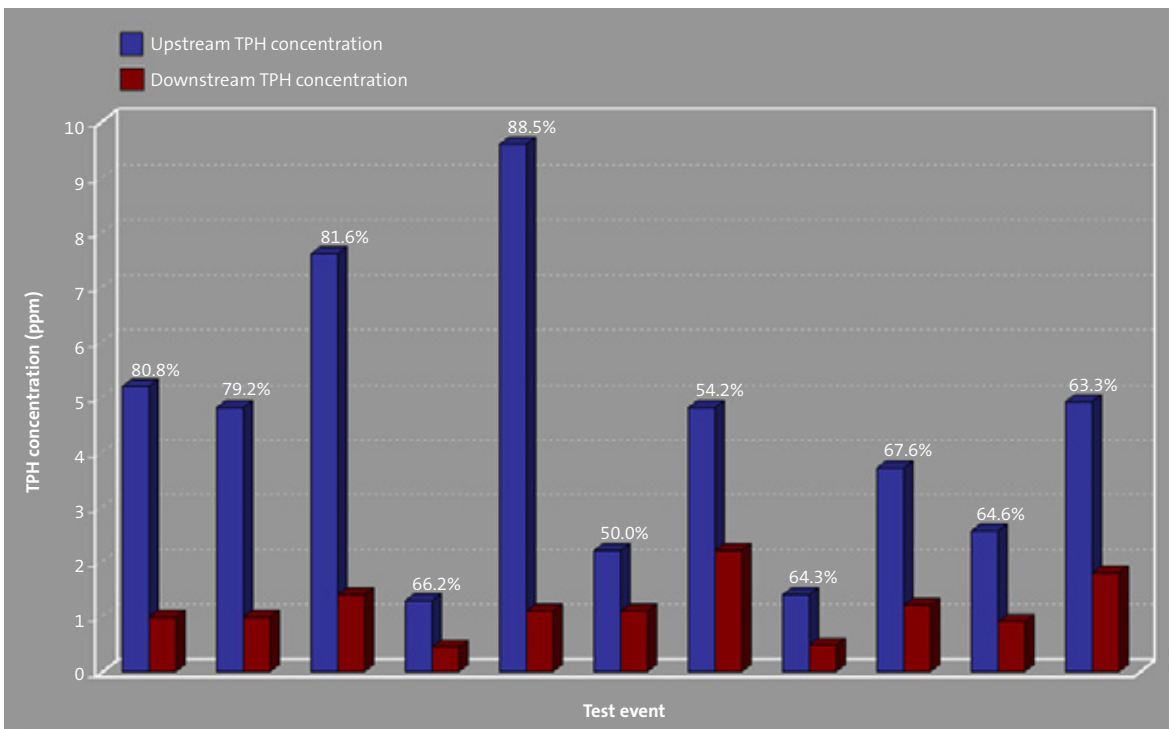

Note: Percentage values represent removal efficiencies

Figure 5 – HumeCeptor® system field performance for Total Petroleum Hydrocarbon (TPH) removal (influent concentration >10 ppm)

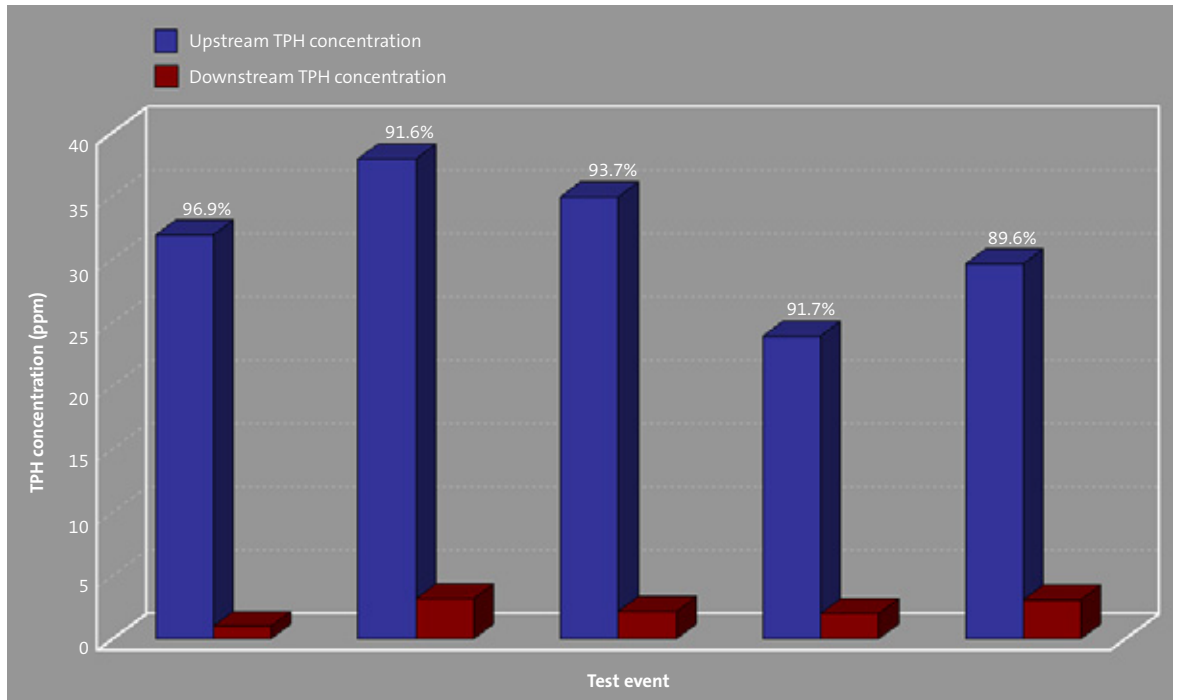

Note: Percentage values represent removal efficiencies

Figure 6 – HumeCeptor® system field performance for Total Petroleum Hydrocarbon (TPH) removal (influent concentration >1,000 ppm)

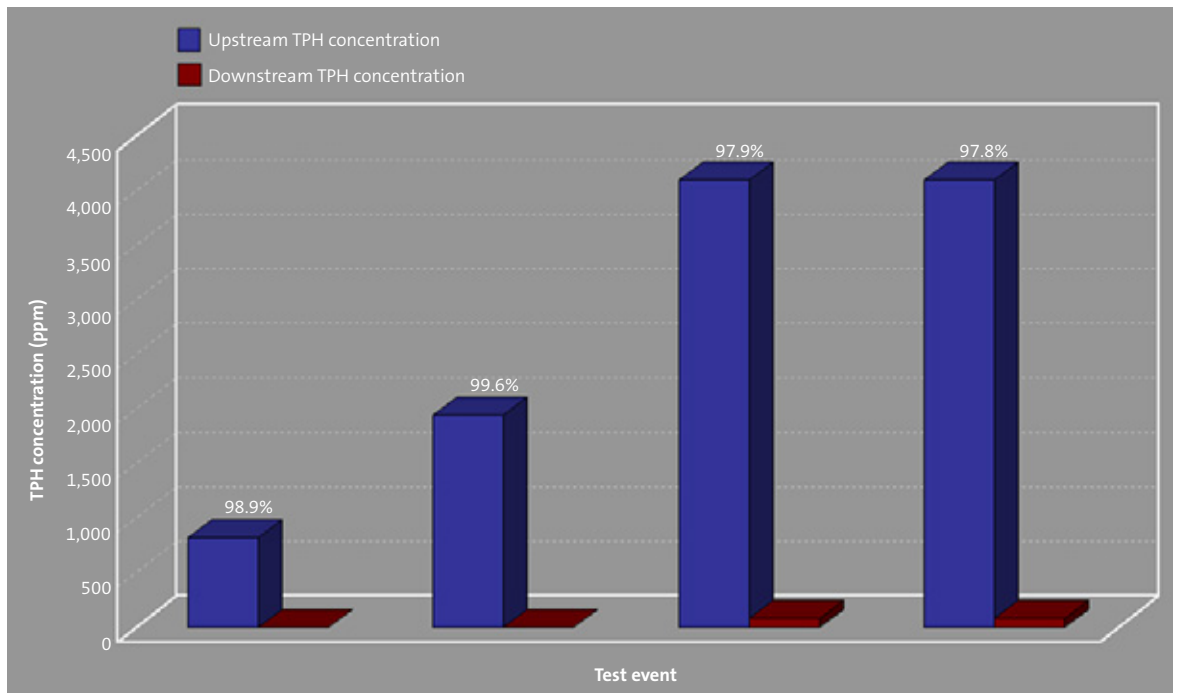

Note: Percentage values represent removal efficiencies

Figure 7 – HumeCeptor® system field performance for Total Phosphorous (TP) removal

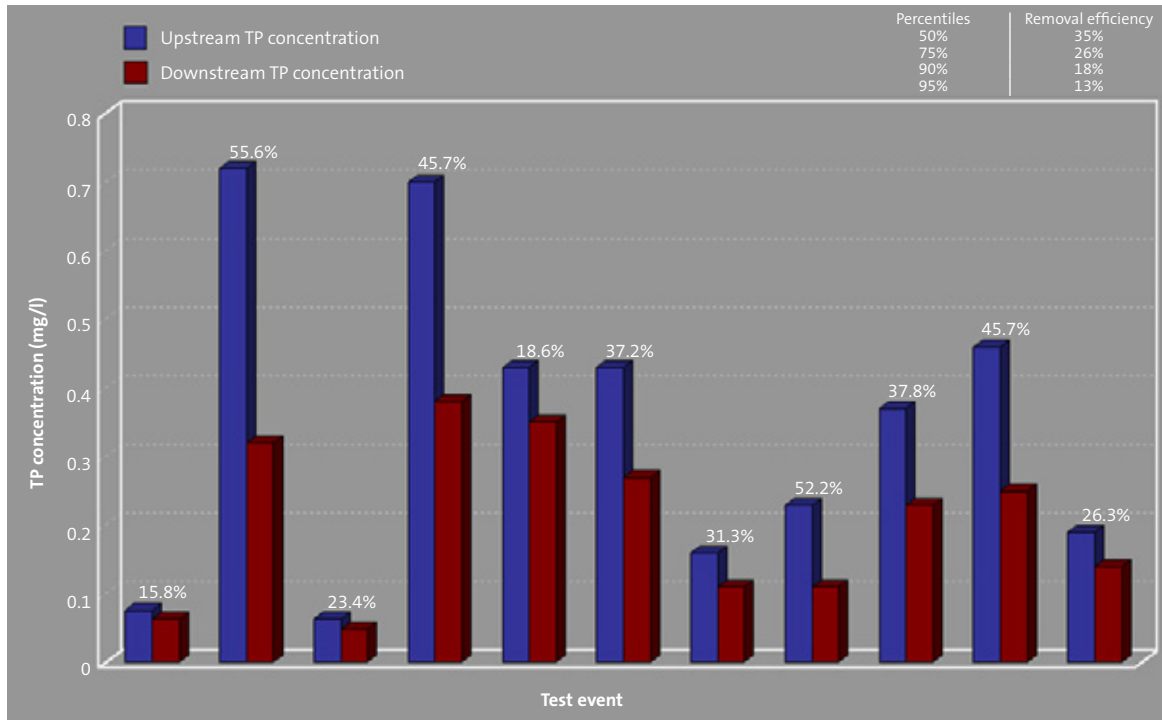

Note: Percentage values represent removal efficiencies

Figure 8 – HumeCeptor® system field performance for Total Nitrogen (TN) removal

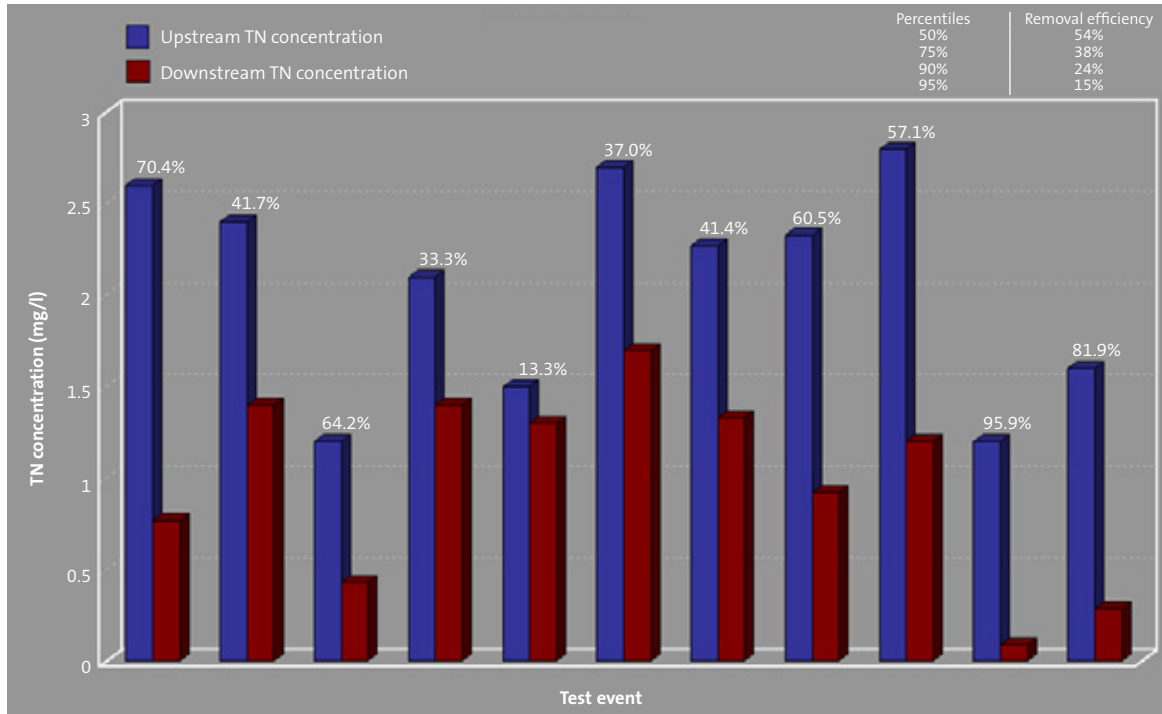

Note: Percentage values represent removal efficiencies

System options

There are a number of HumeCeptor® systems available to meet the requirements of various WQO for maintaining catchments and local hydrology. The standard range is detailed in Table 2 below.

Table 2 – HumeCeptor® model range and details

HumeCeptor® model	Pipe diameter (mm)	Device diameter (mm)	Depth from pipe invert* (m)	Sediment capacity (m³)	Oil capacity (l)	Total storage capacity (l)
STC 2 (inlet)	100 - 600	1,200	1.7	1	350	1,740
STC 3	100 - 1,350	1,800	1.68	2	1,020	3,410
STC 5			2.13	3		4,550
STC 7			3.03	5		6,820
STC 9		2,440	2.69	6	1,900	9,090
STC 14			3.69	10	2,980	13,640
STC 18		3,060	3.44	14		18,180
STC 23			4.04	18		22,730
STC 27			3,600	3.84		20

Note:

*Depths are approximate.

Variants

Continual improvement over the last 14 years of HumeCeptor® system installations has provided a number of enhancements to address specific treatment and design requirements.

- **HumeCeptor® STC 2 (inlet) model**

This model features a grated inlet to directly capture runoff from hardstand areas, replacing the need for a stormwater pit (refer to Figure 9).

Figure 9 – HumeCeptor® STC 2 (inlet) model



- **AquaCeptor™ model**

This model has been designed with a weir extension to increase the level at which flows bypass the treatment chamber, and accommodate downstream tail water levels or periodic inundation (e.g. tidal situations).

This weir extension is provided in standard heights of 100 mm intervals, up to a maximum of 500 mm.

To maintain the hydrocarbon capture capabilities, an additional “high level” inlet pipe is also fitted. This facilitates the formation of the surface vortex from the bypass chamber into the treatment chamber and draws floating hydrocarbons into the unit.

The selection of the appropriate weir extension height is undertaken in conjunction with the downstream engineering design and/or tidal range charts for the specific location. The AquaCeptor™ model is available in the same sizes as the standard HumeCeptor® units (refer Table 2 on the previous page).

Figure 10 – AquaCeptor™ model



- **MultiCeptor™ model**

The MultiCeptor™ model (refer to Figure 11) was developed to facilitate the replacement of junction pits while still providing the treatment abilities of the original HumeCeptor® system and reducing time and costs during installation. These units reverse the weir structure to allow for:

- change of pipe direction
- multiple inlet pipes
- differing invert levels of multiple inlet pipes
- grated inlets.

The MultiCeptor™ model is available in the same sizes as the standard HumeCeptor® units (refer to Table 3 below) and a 2,440 mm diameter MultiCeptor™ unit is also available to accommodate drainage pipes up to 1,800 mm diameter.

The larger insert diameter allows for larger pipe connections that are more common where pipes are laid on very flat grades.

Figure 11 – MultiCeptor™ model



Table 3 – MultiCeptor™ model range and details

HumeCeptor® model	Pipe diameter (mm)	Device diameter (mm)	Depth from pipe invert (m)	Sediment capacity (m ³)	Oil capacity (l)	Total storage capacity (l)		
MI3	100 - 1,350	1,800	1.68	2	1,020	3,410		
MI5			2.13	3		4,550		
MI7			3.03	5		6,820		
MI9		2,440	2,440	2.69	6	1,900	9,090	
MI14				3.69	10		13,640	
MI18			3,060	3,060	3.44	14	2,980	18,180
MI23					4.04	18		22,730
MI27	3,600	3,600	3.84	20	4,290	27,270		
MI9 - MI27 (2,440)	100 - 1,800	2,440 top up to 3,600 base	2.69 - 3.84	6 - 20	1,900 - 4,290	9,090 - 27,270		

• **DuoCeptor™ model**

The DuoCeptor™ model has been developed to treat larger catchments (2 Ha - 6 Ha) because some constrained developments can only accommodate a single, large device instead of several smaller devices.

The unit operates by splitting the flow and treating half of the design flow through the first chamber. The untreated half of the design flow bypasses from the first chamber then passes through the split connection pipe into the second chamber for treatment. Treated flow from the first chamber exits and flows through the other side of the split connection pipe, and bypasses the second chamber to join the treated flow from the second chamber at the outlet of the DuoCeptor™ model.

Figure 12 displays the DuoCeptor™ model and Table 4 details the range of capacities available.

Figure 12 – DuoCeptor™ model



Table 4 – DuoCeptor™ model range and details

DuoCeptor™ model	Pipe diameter (mm)	Device footprint (L x W)	Depth from pipe invert (m)	Sediment capacity (m³)	Oil capacity (l)	Total storage capacity (l)
STC 40	600 - 1,500	7,750 x 3,500	3.41	27	10,585	42,370
STC 50			4.01	35	10,585	50,525
STC 60		9,150 x 4,200	3.89	42	11,560	60,255

- **HumeCeptor® MAX model**

The HumeCeptor® MAX model (refer to Figure 13) was developed to meet the market need for a single, large, end-of-pipe solution for TSS and hydrocarbon removal. Utilising the HumeCeptor® system's proven capture and scour prevention technology, it is ideal for very large commercial and industrial sites (>6 Ha) (eg. quarries, mine sites and stockpile areas) that need to achieve at least 50% TSS removal and hydrocarbon capture. The HumeCeptor® MAX model can be expanded to almost any capacity required.

As the HumeCeptor® MAX model uses two 2,400 mm diameter inserts, sizing must be calculated separately from the PCSWMM software for the HumeCeptor® system. Contact Humes Water Solutions for assistance.

- **HumeCeptor® EOS model**

The HumeCeptor® EOS (Emergency Oil Spill) system provides you with the maximum protection against hydrocarbon spills at petrol stations, highway interchanges and intersections. It combines the passive, always-operating functions of the HumeCeptor® system, with additional emergency storage to capture the volume of spill required by your road authority. Standard designs include 30,000 litres and 50,000 litres of total hydrocarbon storage but these can be modified to suit any specified volume.

Figure 13 – HumeCeptor® MAX model

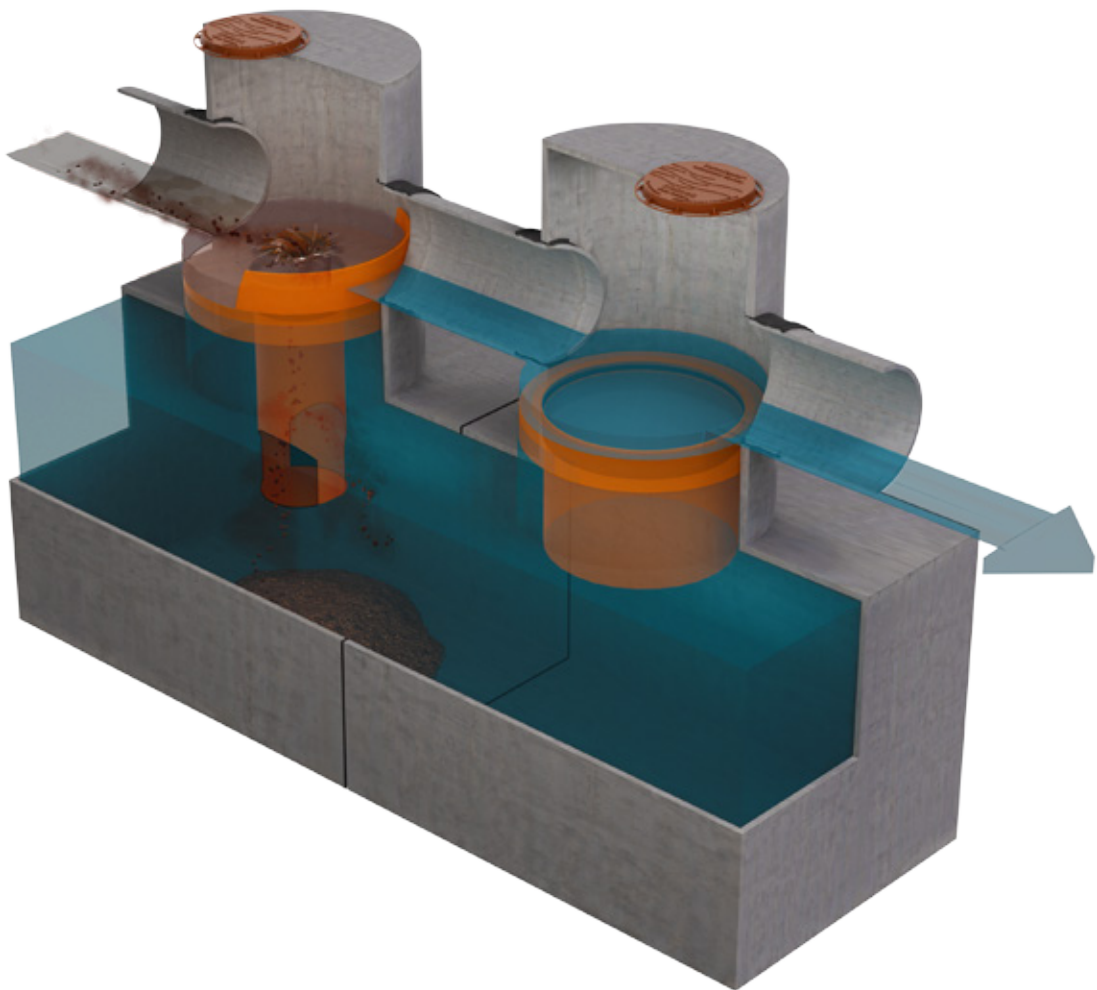

Design information

To design a system suitable for your project it is necessary to review the configuration of the stormwater system, the location and purpose of other stormwater management (WSUD) controls, traffic loading, and the catchment area and hydrology.

Configuration of the stormwater system

As a cylindrical system, HumeCeptor® hydrodynamic separators are much more flexible for accommodating inlet and outlet pipes on angles than rectangular systems.

Location in the stormwater system

Specifically designed for capturing fine sediment and hydrocarbons, the HumeCeptor® system is best suited to “at source” applications. Therefore, it should be located immediately downstream of the catchment area to be treated, e.g. car parks, loading bays, refuelling stations, wash bays.

Catchment area

As a general rule, larger catchment areas require larger HumeCeptor® units. If the catchment area is unstable (e.g. exposed soil) or contributes unusually high pollutant loads (e.g. landscape supply yards), larger units are more appropriate. This can be modelled in PCSWMM software using the “Power Wash-off” or “Event Mean Concentration” TSS loading function.

Sizing HumeCeptor® systems

PCSWMM software for the HumeCeptor® system is the decision support tool used for identifying the appropriate model. A lite version of PCSWMM software is available to identify the HumeCeptor® system which best meets treatment criteria for conventional urban stormwater quality applications (commercial, industrial, residential etc).

Conventional sites typically have stable land cover, paved surfaces, or landscaped areas that do not easily erode during rainfall events. Please contact Humes for further assistance and modeling for unique or unconventional sites. Examples of unconventional sites are as follows:

1. Sites that exhibit unstable wash-off characteristics such as construction sites and sites with material storage. For example, council works depots, landscape supply yards, gravel surfaces etc.
2. Sites with specific suspended solids characteristics such as coal manufacturing facilities, cement manufacturers (sites with a particle size finer or coarser than what is identified in the program).
3. Sites with altered post-development annual hydrology. Alterations to the annual hydrology result from the implementation of stormwater detention upstream of the proposed HumeCeptor® system. Infiltration or detention of small storms (< 1 year) result in alterations to the annual hydrology. Sites with flood control (2 to 100 year detention facilities) will not significantly alter the annual hydrology since detention occurs infrequently. Upstream flood control facilities do not preclude the use of the software for water quality design.

The software calculates continuous runoff from rainfall and simulates sediment accumulation and sediment transport for the design area. Annual TSS removal rates are estimated from the particle size distribution with settling rates calculated using Stoke’s Law, corrected for drag. Assumptions for slope, depression storage, evaporation rates, build-up and wash-off parameters as well as the particle size distribution and settling rates are given in the description of the model calculations.

Users of the software should become familiar with these calculations and parameter values to ensure that they understand the software application. For sites that differ from the assumptions made in the software, please contact your local Humes Water Solutions representative for assistance.

In order to size a unit using the lite version of PCSWMM software, the following six design steps should be followed.

- **Step 1 – Project details and WQOs**

Enter the project details in the appropriate cells, clearly identifying the water quality objectives (WQO) for the development. It is recommended that a level of annual sediment (TSS) removal be identified and defined by a Particle Size Distribution (PSD). In most Australian situations, this WQO is for 80% TSS removal, but a PSD is not defined. This can be determined from relevant research data or from site monitoring.

- **Step 2 – Site details**

Identify the site development by the drainage area and the level of imperviousness. It is recommended that imperviousness be calculated based on the actual area of paved surfaces, sidewalks and rooftops.

- **Step 3 – Upstream detention/retention**

HumeCeptor® systems are designed as a water quality device and is sometimes used in conjunction with on site water quantity control such as ponds or underground detention systems. Where possible, it is more beneficial to install a HumeCeptor® unit upstream of a detention system, as the sediment load is reduced and the maintenance interval between cleaning is maximised.

Where the HumeCeptor® system is installed downstream of a detention system it will alter the hydrology of the catchment and will influence the size of the unit selected by the software. For those projects, enter the footprint area and flow characteristics into the model.

- **Step 4 – Particle Size Distribution (PSD)**

It is critical that the PSD is defined as part of the WQO. The design of the treatment system relies on a Stoke's Law settling (and floating) process, and selection of the target PSD influences the model outcomes.

If the objective is for long term removal of 80% of TSS on a given site, the PSD should be representative of the expected sediment on the site. For example, a system designed to remove 80% of coarse particles (>150 microns) only provides relatively poor removal efficiency of finer particles (<75 microns) that may be naturally present in site runoff. PCSWMM software allows the user to enter their own PSD or select from a range of options in the program (refer to Figure 14 below).

Figure 14 – PCSWMM for HumeCeptor® system - PSD

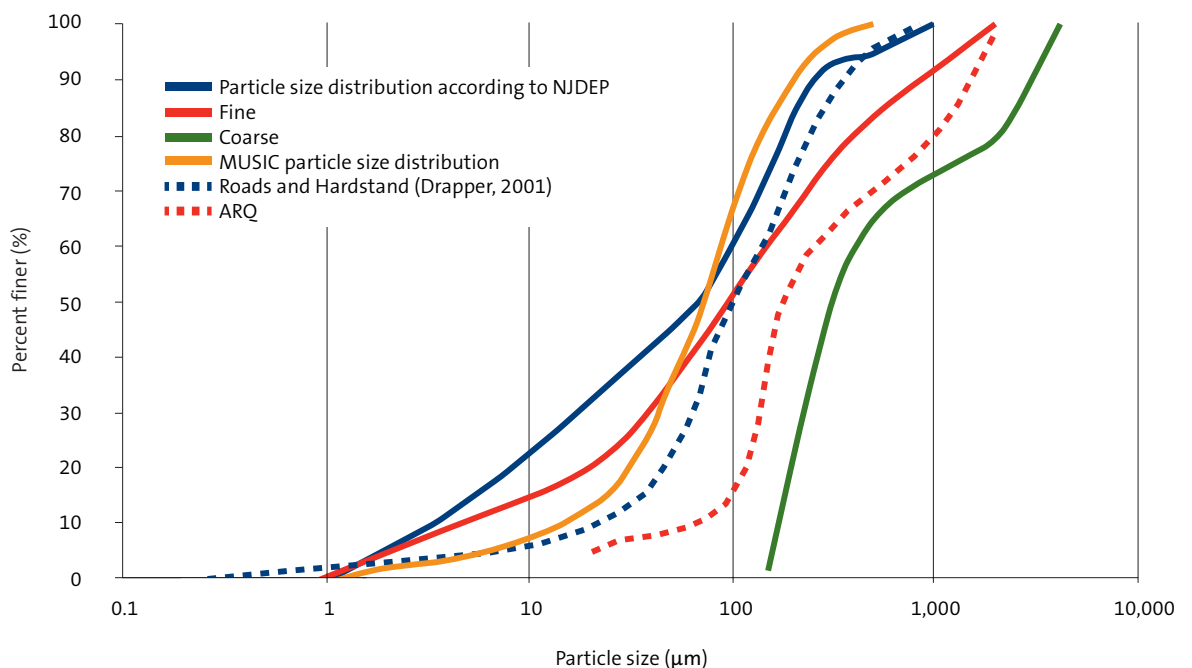

- **Step 5 – Rainfall records**

The rainfall data provided with PCSWMM software provides an accurate storm hydrology estimation by modelling actual historical storm events including duration, intensities and peaks. Local historical rainfall has been acquired from the Bureau of Meteorology. Select the nearest rainfall station from the list.

- **Step 6 – Summary**

At this point, the software is able to predict the level of TSS removal from the site. Once the simulation has been completed, a table is generated identifying the TSS removal of each unit. Based on the WQO identified in Step 1, the recommended HumeCeptor® system unit will be highlighted.

MUSIC/pollutant export model inputs

Many local authorities utilise MUSIC or other pollutant export models to assist in stormwater treatment train selection, and recommend generic inputs for GPTs and hydrodynamic separators.

Considering these against the independent research results in Table 1 on page 4, and PCSWMM modelling used to size a HumeCeptor® unit, the conservative removal efficiencies in Table 5 below are recommended on an annual basis (i.e. no bypass). Humes Water Solutions can optimise the values to suit your specific site.

Table 5 – MUSIC inputs for HumeCeptor® system

Pollutant	Removal efficiency
TSS	80%
TN	30%
TP	30%

System installation

Top:
Installation of
the base section
(step 3)

Middle:
Installation of the
bypass chamber
(step 6)

Bottom:
System ready
for connection
of the inlet and
outlet pipes
(step 8)

The installation of HumeCeptor® units should conform in general to local authority's specifications for stormwater pit construction. Detailed installation instructions are dispatched with each unit.

The HumeCeptor® system is installed as follows:

1. Excavate and stabilise the site.
2. Prepare the geotextile and aggregate base.
3. Install the treatment chamber base section.
4. Install the treatment chamber section/s (if required).
5. Prepare the transition slab (if required).
6. Install the bypass chamber section.
7. Fit the inlet drop pipe and decant pipe (if required).
8. Connect inlet and outlet pipes as required.
9. Backfill to transition slab level.
10. Install the maintenance access chamber section (if required).
11. Install the frame and access cover/grate.
12. Backfill to finished surface/base course level and complete surface pavement.



System maintenance

The design of the HumeCeptor® system means that maintenance is conducted with a vacuum truck which avoids entry into the unit.

If the HumeCeptor® unit is sized using the PCSWMM guidelines, a maximum interval of annual maintenance is recommended.

A typical maintenance procedure includes:

1. Open the access cover.
2. Insert the vacuum hose into the top of the treatment chamber via the decant (outlet) pipe.
3. Remove the oily water until the level is just below the lower edge of the decant pipe.
4. Lower a sluice gate into the nearest upstream junction pit and decant the water from the treatment chamber into the upstream pit until the sediment layer is exposed.
5. Remove the sediment layer into the vacuum truck for disposal.
6. Raise the upstream sluice gate and allow water to return into the HumeCeptor® unit.
7. Replace the access cover.

FAQs

• Will it capture litter?

The HumeCeptor® system is primarily designed for hydrocarbon and fine sediment removal, so if litter is expected from the catchment an upstream GPT is recommended. However, items such as cigarette butts, plastic bags and smaller gross pollutants will be captured by the system.

• Do I need to model a bypass flow for the HumeCeptor® system in MUSIC?

No, PCSWMM software for the HumeCeptor® system analyses all flows from the catchment to determine 80% TSS removal on an annual basis. Therefore, the output efficiency of PCSWMM for the selected model can be incorporated into a MUSIC treatment node without a bypass flow.

• How often do I need to undertake maintenance?

A maximum interval of 12 months is recommended, with 3 months ideal, however, these systems are designed with a factor of safety, so it will continue to retain sediment until it is completely full.

• What if the PSD from my site is different to those in the software?

Humes Water Solutions has the ability to model a user-defined PSD in PCSWMM software for the HumeCeptor® system. If you have PSD results contact us for assistance.

• Do I have to use the model that PCSWMM software highlights?

No, in most stormwater treatment trains, there are other measures upstream and/or downstream. Select the unit size that you need to achieve your desired removal efficiency in the context of your overall concept. Remember that selecting a model that removes less TSS will also remove less TN and TP.

• Is it possible to change the hydrology model defaults in PCSWMM?

Yes, Humes Water Solutions has the ability to vary these inputs. Please contact us for further assistance.

• Will the HumeCeptor® system's treatment chamber release nutrients?

Over time, captured organic material will break down and release nutrients in all treatment measures whether natural or manufactured. As part of a treatment train, downstream natural measures can remove the small portion of nutrients released during dry weather flows. A regular maintenance program will reduce the amount of break down occurring (Ball and Powell, 2006).

- **Why is the HumeCeptor® system not sized on flow rate?**

The HumeCeptor® system is sized using actual historical rainfall and an algorithm based on research (Novotny and Chesters 1981, Charbeneau and Barrett, 1988, Ball and Abustan 1995, Sartor and Boyd 1972) showing that pollutants build up and wash off a catchment which is influenced by time, Particle Size Distribution (PSD), rainfall volume and intensity. These form a pollutograph that the software uses to calculate the HumeCeptor® system performance for all flows in every event over the rainfall period. The software then recommends the model that will remove a user selected removal target (usually set to 80%) of TSS load from all of these events.

- **How is the HumeCeptor® system different to a GPT?**

The HumeCeptor® system is specifically designed to target fine sediment and hydrocarbons. Therefore, it is designed to maintain velocities through the treatment chamber <0.02 m/s. A GPT is designed to capture gross pollutants (>1 mm). For a GPT to function in an equivalent way to a HumeCeptor® system, the treatment chamber velocity must be <0.02 m/s.

- **Why would I use a HumeCeptor® system upstream of a biofilter?**

Using a HumeCeptor® system upstream of a biofilter acts as a non-scouring sediment forebay, containing sediment to a confined location for easy removal. This protects the biofilter and lengthens its lifespan.

References

- Novotny, V and Chesters, G (1981) "Handbook of Non-Point Pollution Sources and Management", John Wiley and Sons, New York.
- Charbeneau, RJ and Barrett, M.E (1998) "Evaluation of Methods for Estimating Stormwater Pollutant Loads", Water environment research 70 (7): 1,295 - 1,302.
- Ball, J and Abustan, I (1995) "An Investigation of the Particle Size Distribution During Storm Events on an Urban Catchment", Prol. the 2nd Int. Symposium on Urban Stormwater Management 1995 pp 531 - 535, IEAUST, Melbourne, Nat. Conf. Pub. 95/3.
- Sartor, J.D and Boyd, G.B (1972) "Water Pollutant Aspects of Street Surface Contaminants", US EPA (EPA - R2 - 72 - 081) Washington, DC.
- Ball, J and Powell, M (2006) "Influence of Anaerobic Breakdown on the Selection of Appropriate Urban Stormwater Management Measures", SIA Annual Conference.
- Schueler, Tom and David Shepp (1993) "The Quality of Trapped Sediments and Pool Water Within Oil Grit Separators in Suburban Maryland", Metropolitan Council of Governments.

Appendix

HumeCeptor® system technical drawings

ISSUE		DETAILS OF ALTERATIONS		DWG	DATE	OD
0	ISSUED FOR MANUFACTURE	AGE	15.05.21	50°C		
1	UPDATED AND REISSUED FOR MANUFACTURE	M.Z.	12.11.21	DFW		
2	GENERAL UPGRADE	RM	11.08.23	DFW		

NOTES:

1. TYPICAL ASSEMBLY DETAIL ONLY - REFER TO PROJECT DRAWING FOR ACTUAL REQUIREMENTS
2. DIMENSIONS INCLUDED ARE STANDARD
3. STORAGE VOLUMES
TOTAL = 1740 LITRES
OIL STORAGE VOLUME = 350 LITRES
SEDIMENT STORAGE VOLUME = 1,34m³
4. COMPONENT MASSES
TREATMENT CHAMBER BASE UNIT (INCL. SHAFT) = 1130 kg
BYPASS CHAMBER = VARIES
BYPASS CHAMBER CONVERTER SLAB = 575 kg
5. REFER TO BYPASS CHAMBER ASSEMBLY DRAWING FOR FIXING DETAILS FOR FIBREGLASS INSERT.
6. FOR OUTLET PIPE CONNECTION DETAILS REFER HC-BC-A5 OR A6 AND KOR-N-SEAL INSTALLATION INSTRUCTIONS
7. SWIFTLIFT LIFTING ANCHORS PROVIDED FOR LIFTING ALL COMPONENTS (REFER PRODUCT DRAWING)
8. JOINT SEALANT AS PER MANUFACTURERS RECOMMENDATIONS.

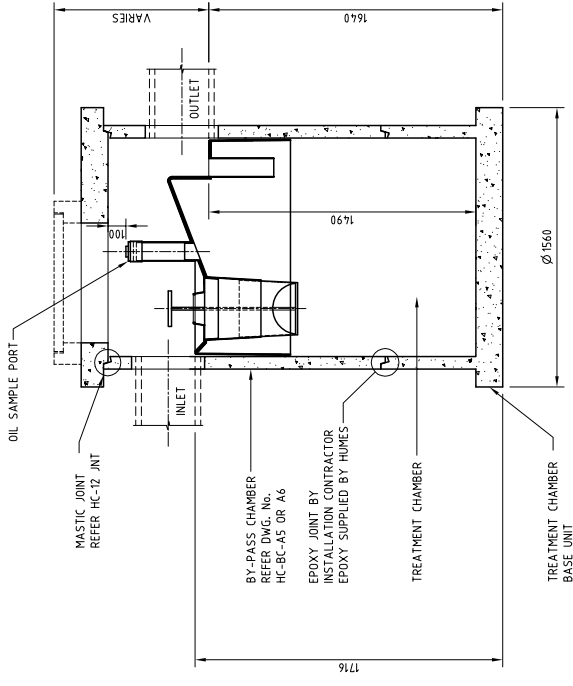

NOTE: STANDARD DROP INLET TO OUTLET IS 76mm

SECTION
SCALE 1:20

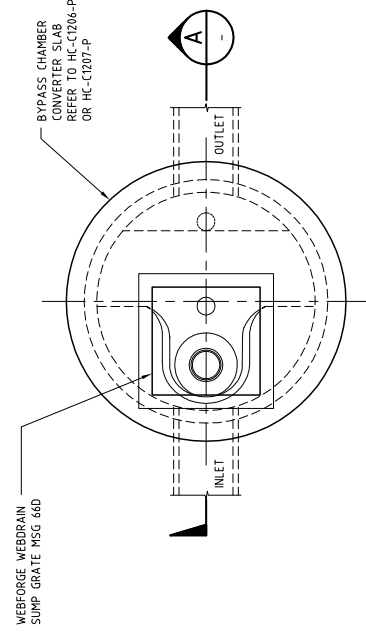

PLAN - SQUARE OPENING
(PREFERRED)
SCALE 1:20

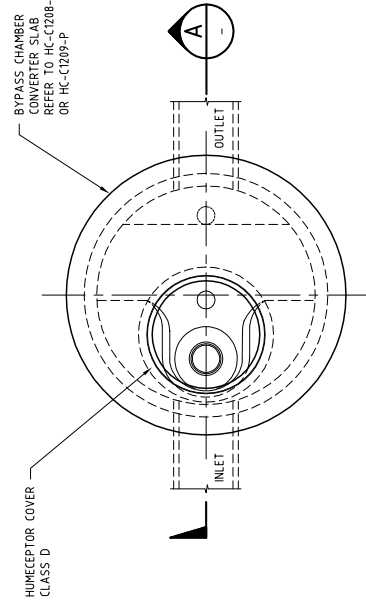

PLAN - CIRCULAR OPENING
(ALTERNATIVE)
SCALE 1:20



TECHNICAL (DESIGN) SERVICES
BRISBANE, QUEENSLAND

	50°C	12.11.21
	DWG	12.11.21
	50°C	12.11.21
	APP.	12.11.21

HUMCEPTOR™ STANDARD DRAWING™ STC-2 HUMCEPTOR™ c/w INLET AND OUTLET PIPES ASSEMBLY DRAWING		FIG. NO.	A2	HC-STC2-B	2
ISSUE	1:20	SCALE	A2	HC-STC2-B	2

Readymix Holdings Pty Limited
 ASH 111 001 132 297
 PRIVATE DESIGN: This drawing remains the property of Readymix Holdings Pty Limited and is subject to recall immediately upon request. It must not be loaned, copied or reproduced in any form without the permission of Readymix Holdings Pty Limited.

REV	DETAILS OF ALTERATIONS	DATE	BY	CHKD
0	UPDATED AND ISSUED FOR MANUFACTURE		M.Z.	P.R.-P
1	STORAGE VOLUMES REVISED		M.Z.	P.R.-P

NOTES:

1. TYPICAL ASSEMBLY DETAIL ONLY - REFER TO PROJECT DRAWING FOR ACTUAL REQUIREMENTS
2. DIMENSIONS INCLUDED ARE STANDARD
3. STORAGE VOLUMES:
 TOTAL STORAGE VOLUME = 3540 LITRES
 OIL STORAGE VOLUME = 1079 LITRES
 SEDIMENT STORAGE VOLUME = 2200L 
4. COMPONENT MASSES:
 TREATMENT CHAMBER BASE UNIT (INCL. SHAFT) = 3.9 TONNE
 BYPASS CHAMBER = VARIES
 BYPASS CHAMBER CONVERTER SLAB = 1.9 TONNE
5. REFER TO BYPASS CHAMBER ASSEMBLY DRAWING FOR FIXING DETAILS FOR FIBREGLASS INSERT.
6. BYPASS CHAMBER CONVERTER SLAB TO SUIT LOCAL ACCESS CHAMBER UNITS.
7. FOR INLET AND OUTLET PIPE CONNECTION DETAILS REFER HC-B52-A1 OR A2 AND KOR-NI-SEAL INSTALLATION INSTRUCTIONS
8. SWIFTLIFT LIFTING ANCHORS PROVIDED FOR LIFTING ALL COMPONENTS (REFER PRODUCT DRAWING)
9. NOTE MARKINGS - INLET & OUTLET OVER EACH
10. JOINT SEALANT AS PER MANUFACTURERS RECOMMENDATIONS.
11. OIL SAMPLE PORT AND DECANT PIPE TO BE VISIBLE AS PER PLAN VIEW.

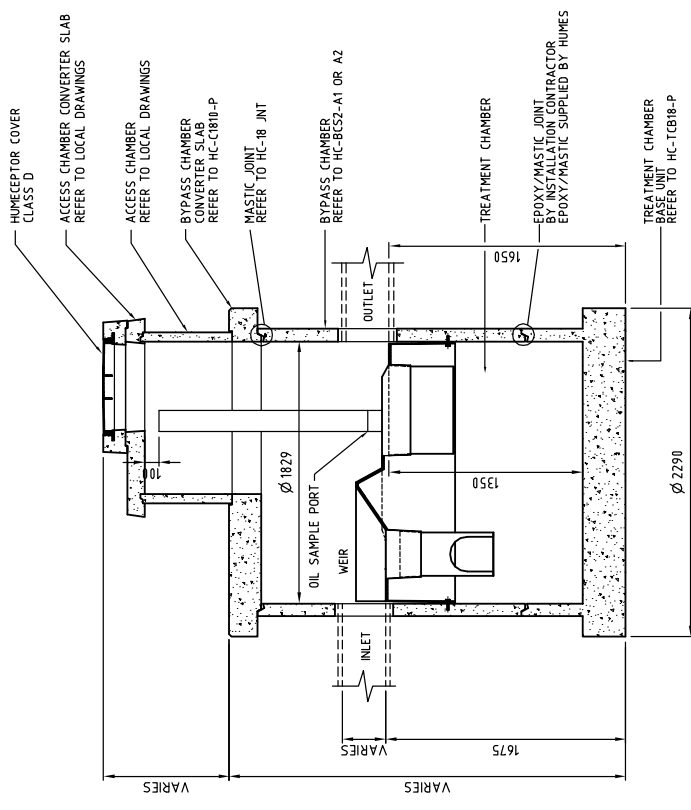

SECTION A
SCALE 1:25

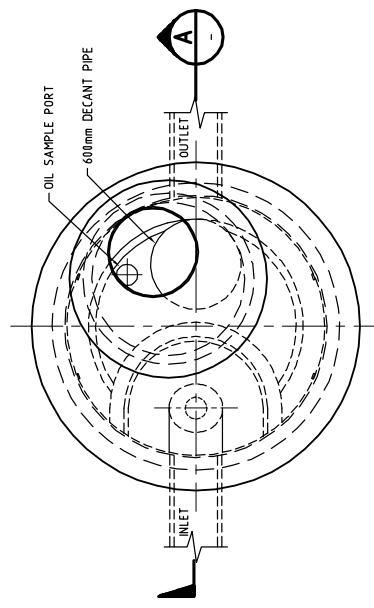

PLAN
SCALE 1:25

humes TECHNICAL (DESIGN) SERVICES
BROSBANE, QUEENSLAND

HUMECEPTOR™
STANDARD DRAWING
STC-3 HUMECEPTOR
ASSEMBLY DRAWING

REV	DATE	BY	CHKD
0		M.Z.	P.R.-P
1		M.Z.	P.R.-P

PROJECT NO.	SCALE	SIZE	REV
	1:25	A2	1

Background Holdings Pty Limited JUL 97 19:33:27
 PLEASE NOTE: This drawing is the property of Background Holdings Pty Limited and is subject to recall immediately upon request. It must not be loaned, copied or otherwise used for any means without permission of Background Holdings Pty Limited.

ISSUE	DETAILS OF ALTERATIONS	DATE	BY
0	UPDATED AND ISSUED FOR MANUFACTURE	13/04/18	DFW

NOTES:

1. TYPICAL ASSEMBLY DETAIL ONLY - REFER TO PROJECT DRAWING FOR ACTUAL REQUIREMENTS
2. DIMENSIONS INCLUDED ARE STANDARD
3. STORAGE VOLUMES
TOTAL = 4720 LITRES
OIL STORAGE VOLUME = 1020 LITRES
SEDIMENT STORAGE VOLUME = 3380S
4. COMPONENT MASSES
TREATMENT CHAMBER BASE UNIT (INCL. SHAFT) = 4.4 TONNE
BYPASS CHAMBER = VARIES
BYPASS CHAMBER CONVERTER SLAB = 1.9 TONNE
FOR FIBREGLASS INSERT.
5. REFER TO BYPASS CHAMBER ASSEMBLY DRAWING FOR FIXING DETAILS
6. BYPASS CHAMBER CONVERTER SLAB TO SUIT LOCAL ACCESS CHAMBER UNITS.
7. FOR INLET AND OUTLET PIPE CONNECTION DETAILS REFER HC-BC52-A1 OR A2 AND KOR-N-SEAL INSTALLATION INSTRUCTIONS (REFER PRODUCT DRAWING)
8. SWIFTLIFT LIFTING ANCHORS PROVIDED FOR LIFTING ALL COMPONENTS (REFER PRODUCT DRAWING)
9. NOTE MARKINGS - INLET & OUTLET OVER EACH
10. JOINT SEALANT AS PER MANUFACTURERS RECOMMENDATIONS.
11. OIL SAMPLE PORT AND DECANT PIPE TO BE VISIBLE AS PER PLAN VIEW.

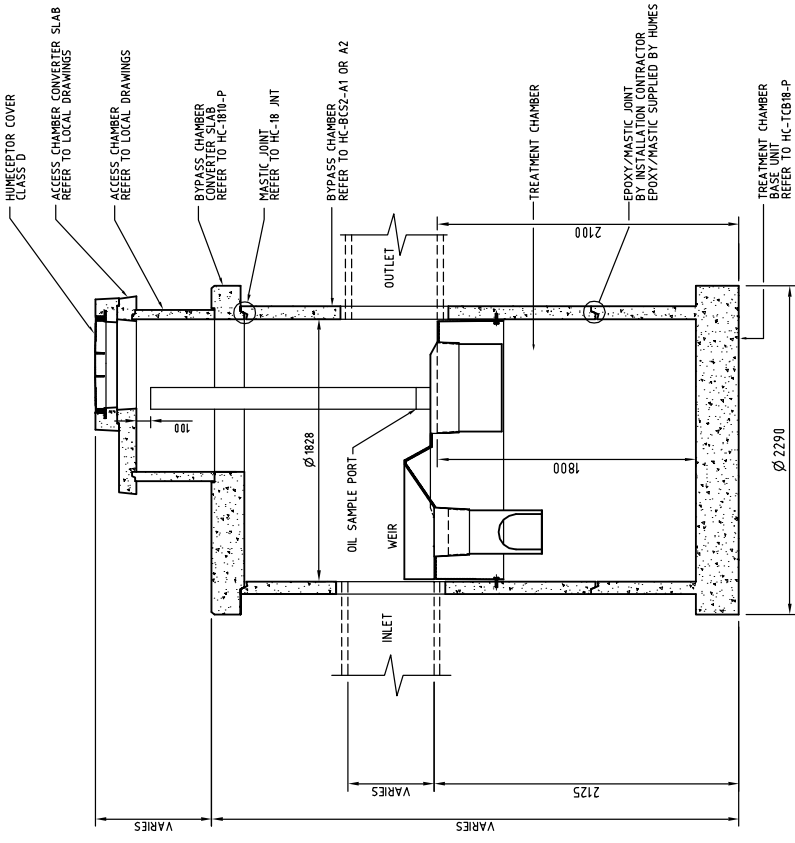

SECTION A-A
SCALE 1:25

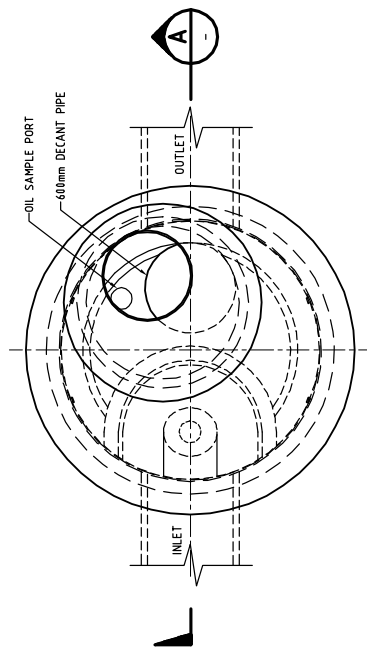

PLAN
SCALE 1:25



TECHNICAL (DESIGN) SERVICES
BRISBANE, QUEENSLAND

DFW	18/04/18
M.Z.	18/04/18
DFW	18/04/18
DFW	18/04/18

Reinforced Concrete Pty Limited ABN 61 699 732 297
The design and construction of this structure is the property of Reinforced Concrete Pty Limited and is subject to their intellectual property rights. This drawing is not to be copied or reproduced in any form or by any means without permission of Reinforced Concrete Pty Limited.

HUMECEPTOR™
STANDARD DRAWING
STC-5 HUMECEPTOR
ASSEMBLY DRAWING
FIG. NO. **A2 HC-STC5-A** 0

SCALE	1:25
DATE	

NO.	DETAILS OF ALTERATIONS	DATE	BY
0	UPDATED AND ISSUED FOR MANUFACTURE	M.Z. 13/12/18	DFW

NO.	DATE	BY

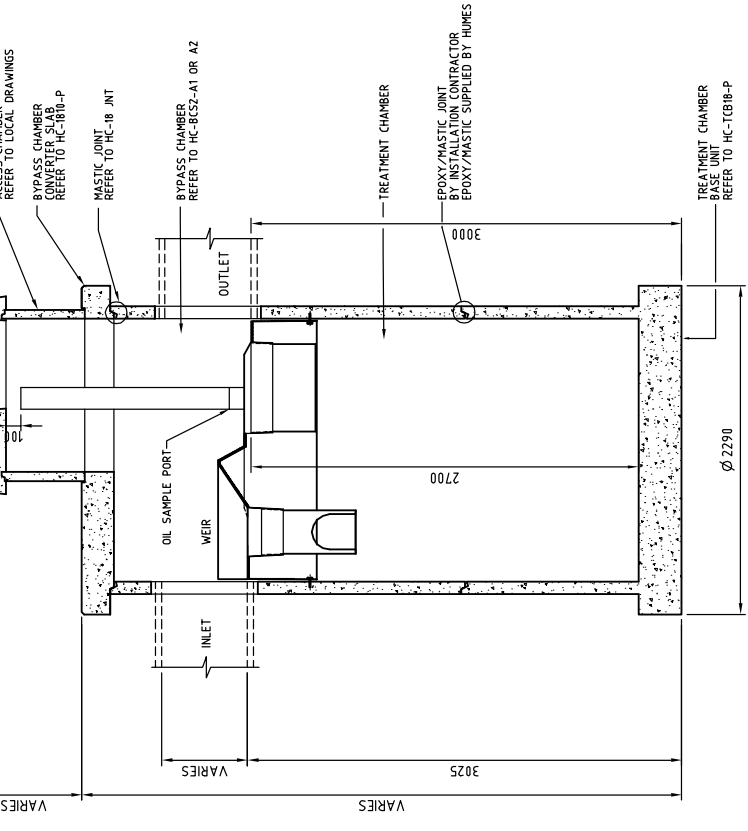

SECTION A
SCALE 1:25

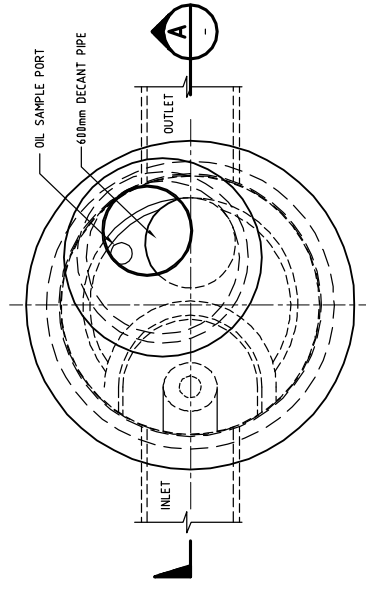

PLAN
SCALE 1:25

- NOTES:**
1. TYPICAL ASSEMBLY DETAIL ONLY - REFER TO PROJECT DRAWING FOR ACTUAL REQUIREMENTS
 2. DIMENSIONS INCLUDED ARE STANDARD
 3. STORAGE VOLUMES
 TOTAL = 7080 LITRES
 OIL STORAGE VOLUME = 1020 LITRES
 SEDIMENT STORAGE VOLUME = 5.74m3
 4. COMPONENT MASSES
 BYPASS CHAMBER BASE UNIT (INCL. SHAFT) = 5.1 TONNE
 BYPASS CHAMBER VARGES
 BYPASS CHAMBER CONVERTER SLAB = 1.9 TONNE
 5. REFER TO BYPASS CHAMBER ASSEMBLY DRAWING FOR FIXING DETAILS FOR FIBREGLASS INSERT.
 6. BYPASS CHAMBER CONVERTER SLAB TO SUIT LOCAL ACCESS CHAMBER UNITS.
 7. FOR INLET AND OUTLET PIPE CONNECTION DETAILS REFER HC-BCS2-A1 OR A2 AND KOR-N-SEAL INSTALLATION INSTRUCTIONS (REFER PRODUCT DRAWING)
 8. SWIFTLIFT LIFTING ANCHORS PROVIDED FOR LIFTING ALL COMPONENTS (REFER PRODUCT DRAWING)
 9. NOTE MARKINGS - INLET & OUTLET OVER EACH
 10. JOINT SEALANT AS PER MANUFACTURERS RECOMMENDATIONS.
 11. OIL SAMPLE PORT AND DECANT PIPE TO BE VISIBLE AS PER PLAN VIEW.



TECHNICAL (DESIGN) SERVICES
 BRISBANE, QUEENSLAND

	DFW 13/12/18	DFW 13/12/18	DFW 13/12/18	DFW 13/12/18
	M.Z. 13/12/18	M.Z. 13/12/18	M.Z. 13/12/18	M.Z. 13/12/18
	DFW 13/12/18	DFW 13/12/18	DFW 13/12/18	DFW 13/12/18
	DFW 13/12/18	DFW 13/12/18	DFW 13/12/18	DFW 13/12/18
HUMECEPTOR™ STANDARD DRAWING STC-7 HUMECEPTOR ASSEMBLY DRAWING				ISSUE NO. A2 HC-STC7-A 0
PROJECT SCALE 1:25				ISSUE NO. A2 HC-STC7-A 0

Resolute Holdings Pty Limited
 All rights reserved. This drawing, or any part thereof, is the property of Resolute Holdings Pty Limited. It may not be copied, reproduced, or transmitted in any form or by any means without the prior written permission of Resolute Holdings Pty Limited.

2003

ISSUE	DETAILS OF ALTERATIONS	DATE	BY	APP'D
0	UPDATED AND ISSUED FOR MANUFACTURE	13-10-18	M.Z.	DFW

NOTES:

1. TYPICAL ASSEMBLY DETAIL ONLY - REFER TO PROJECT DRAWING FOR ACTUAL REQUIREMENTS
2. DIMENSIONS INCLUDED ARE STANDARD
3. STORAGE VOLUMES
TOTAL = 9260 LITRES
OIL STORAGE VOLUME = 1900 LITRES
OIL SEDIMENT STORAGE VOLUME = 6.81 m³
4. COMPONENT MASSES
TREATMENT CHAMBER BASE UNIT (INCL. SHAFT) = 7.7 TONNE
TREATMENT CHAMBER TOP UNIT (CONV. SLAB + SHAFT) = 6.0 TONNE
BYPASS CHAMBER = VARIES
5. REFER TO BYPASS CHAMBER ASSEMBLY DRAWING FOR FIXING DETAILS FOR FIBREGLASS INSERT.
6. BYPASS CHAMBER CONVERTER SLAB TO SUIT LOCAL ACCESS CHAMBER UNITS.
7. FOR INLET AND OUTLET PIPE CONNECTION DETAILS REFER HC-BC52-A1 OR A2 AND KOR-N-SEAL INSTALLATION INSTRUCTIONS.
8. SWIFTLIFT LIFTING ANCHORS PROVIDED FOR LIFTING ALL COMPONENTS. (REFER PRODUCT DRAWING)
9. NOTE MARKINGS - INLET AND OUTLET OVER EACH.
10. JOINT SEALANT AS PER MANUFACTURERS RECOMMENDATIONS.
11. OIL SAMPLE PORT AND DECANT PIPE TO BE VISIBLE AS PER PLAN VIEW.

RUBBER RING JOINT SPECIFICATION	
MATERIAL	: NITRILE
HARDNESS	: 43 ± 3 IRHD (AS 1646)
PROFILE	: L25 (REFER Dwg. J1001-01)
ID	: 2225 ± 10mm

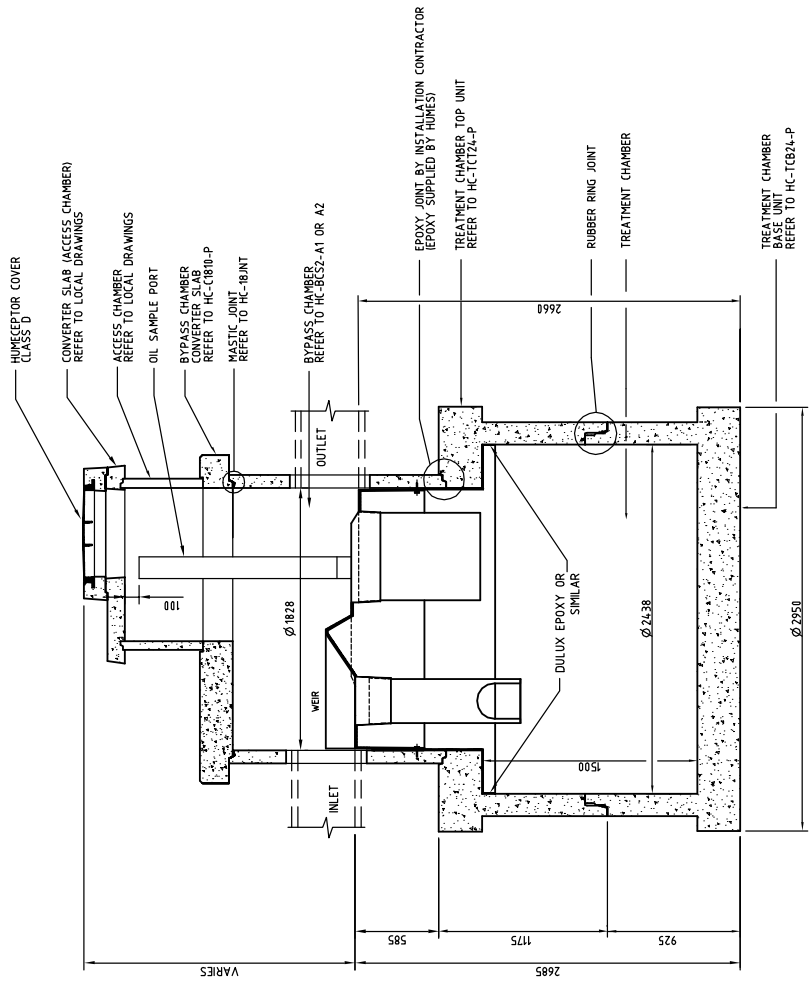

SECTION A
SCALE 1:25

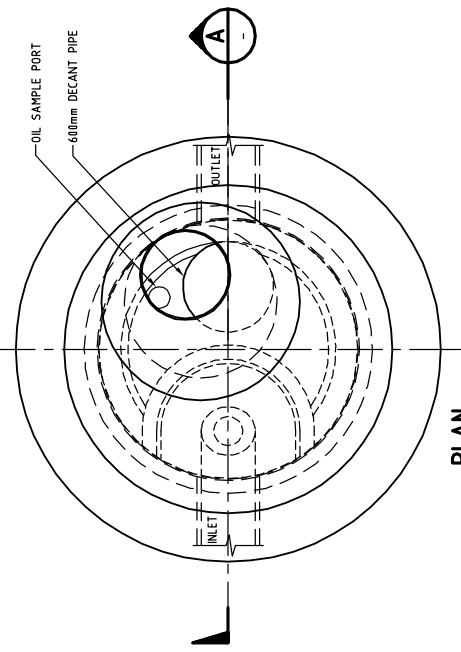

PLAN
SCALE 1:10

Humes TECHNICAL (DESIGN) SERVICES
BRISBANE, QUEENSLAND

HUMCEPTOR™
STANDARD DRAWING
STC-9 HUMCEPTOR
ASSEMBLY DRAWING

REV	DATE	BY	APP'D
1	1/25	M.Z.	DFW

PROJECT NO. **A2 HC-STC-9-A**
SCALE **0**

Backgrounds Holdings Pty Limited (ABN 61 191 732 297)
This drawing is the property of Backgrounds Holdings Pty Limited and is subject to recall immediately upon request. It must not be loaned, copied or communicated in any form or by any means without permission of Backgrounds Holdings Pty Limited.

ISSUE	DETAILS OF ALTERATIONS	DATE	BY	APP'D
0	UPDATED AND ISSUED FOR MANUFACTURE	13-10-13	M.Z.	DFW

NOTES:

1. TYPICAL ASSEMBLY DETAIL ONLY - REFER TO PROJECT DRAWING FOR ACTUAL REQUIREMENTS
2. DIMENSIONS INCLUDED ARE STANDARD
3. STORAGE VOLUMES
TOTAL = 19220 LITRES
OIL STORAGE VOLUME = 2980 LITRES
SEDIMENT STORAGE VOLUME = 10.27 m³
4. COMPONENT MASSES
TREATMENT CHAMBER BASE UNIT (INCL. SHAFT) = 7.9 TONNE
TREATMENT CHAMBER TOP UNIT (CONV. SLAB + SHAFT) = 6.1 TONNE
BYPASS CHAMBER = VARIES
TREATMENT CHAMBER SHAFT = 2.8 TONNE
5. REFER TO BYPASS CHAMBER ASSEMBLY DRAWING FOR FIXING DETAILS FOR FIBREGLASS INSERT.
6. BYPASS CHAMBER CONVERTER SLAB TO SUIT LOCAL ACCESS CHAMBER UNITS.
7. FOR INLET AND OUTLET PIPE CONNECTION DETAILS REFER HC-BCS2-A1 OR A2 AND KOR-N-SEAL INSTALLATION INSTRUCTIONS
8. SWEETLET LIFTING ANCHORS PROVIDED FOR LIFTING ALL COMPONENTS (REFER PRODUCT DRAWINGS)
9. NOTE MARKINGS - INLET AND OUTLET OVER EACH.
10. JOINT SEALANT AS PER MANUFACTURERS RECOMMENDATIONS.
11. OIL SAMPLE PORT AND DECANT PIPE TO BE VISIBLE AS PER PLAN VIEW.

RUBBER RING JOINT SPECIFICATION
 MATERIAL: NITRILE
 HARDNESS: 43 ± 3 IRHD (AS1646)
 PROFILE : L25 (REFER Dwg. J1001-01)
 ID : 2225 ± 16mm

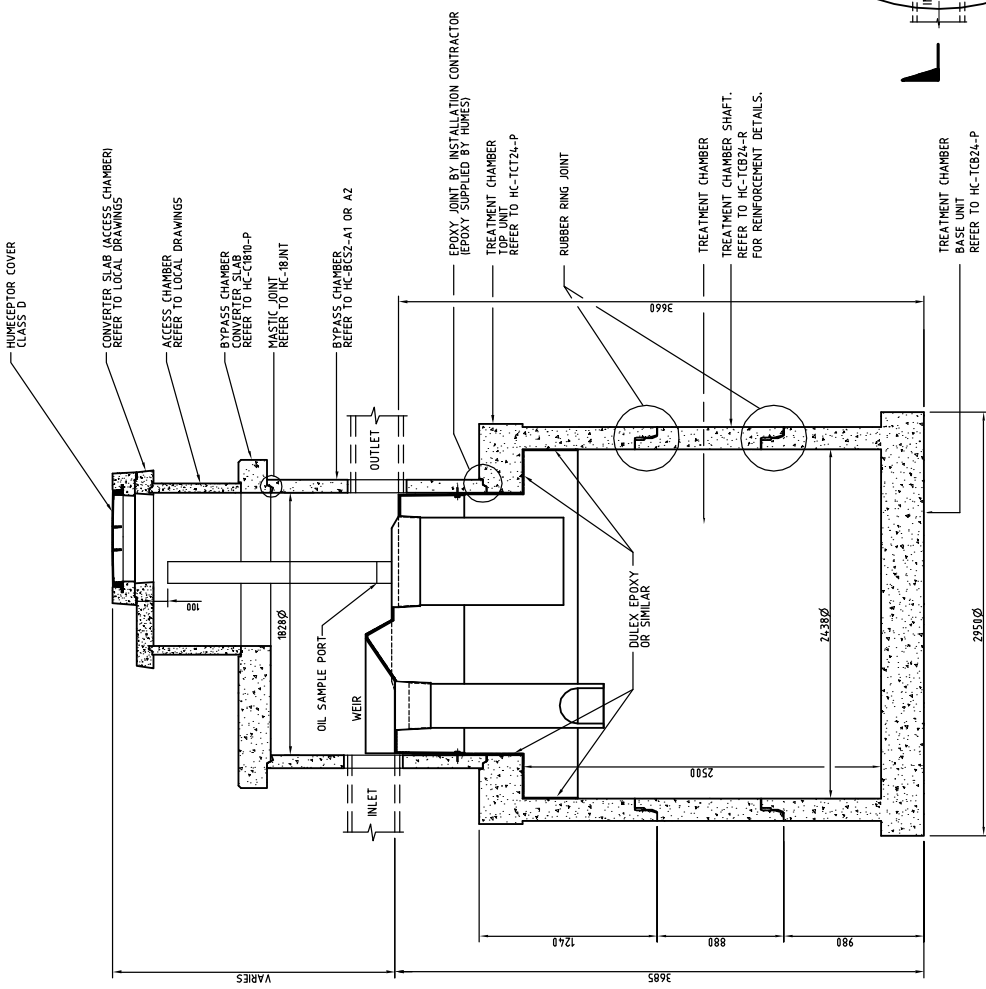
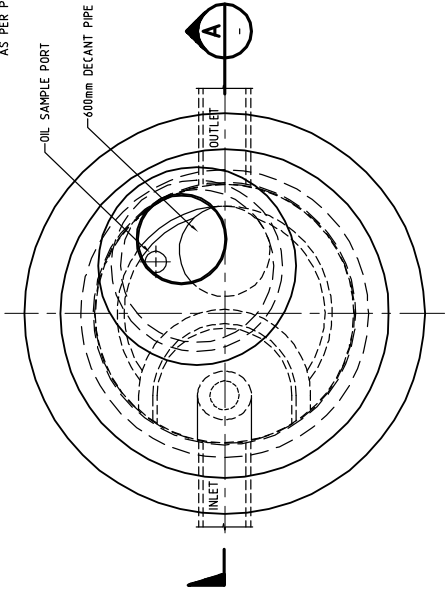

SECTION A-A
 SCALE 1:25

PLAN
 SCALE 1:25

Humes TECHNICAL (DESIGN) SERVICES
 BRISBANE, QUEENSLAND

DFW	DFW	DFW	DFW	DFW	DFW	DFW	DFW
13-10-13	13-10-13	13-10-13	13-10-13	13-10-13	13-10-13	13-10-13	13-10-13
M.Z.	M.Z.	M.Z.	M.Z.	M.Z.	M.Z.	M.Z.	M.Z.
DFW	DFW	DFW	DFW	DFW	DFW	DFW	DFW
13-10-13	13-10-13	13-10-13	13-10-13	13-10-13	13-10-13	13-10-13	13-10-13
M.Z.	M.Z.	M.Z.	M.Z.	M.Z.	M.Z.	M.Z.	M.Z.
DFW	DFW	DFW	DFW	DFW	DFW	DFW	DFW
13-10-13	13-10-13	13-10-13	13-10-13	13-10-13	13-10-13	13-10-13	13-10-13
M.Z.	M.Z.	M.Z.	M.Z.	M.Z.	M.Z.	M.Z.	M.Z.
DFW	DFW	DFW	DFW	DFW	DFW	DFW	DFW
13-10-13	13-10-13	13-10-13	13-10-13	13-10-13	13-10-13	13-10-13	13-10-13
M.Z.	M.Z.	M.Z.	M.Z.	M.Z.	M.Z.	M.Z.	M.Z.

HUMECEPTOR™
 STANDARD DRAWING
STC-14 HUMECEPTOR
 ASSEMBLY DRAWING
 SHEET NO. **A2** OF **HC-STC14-A 0**

2003

Reinforced Polyethylene (AS 1911:2011) must be used for all components. The property of Reinforced Polyethylene is subject to local conditions. It must not be heated, copied or reproduced in any form or by any means without permission of Humes Holdings Pty Limited.

ISSUE	DETAILS OF ALTERATIONS	DATE	BY	APP'D
0	UPDATED AND ISSUED FOR MANUFACTURE	M.Z.	B-J	DFW

- NOTES:**
1. TYPICAL ASSEMBLY DETAIL ONLY - REFER TO PROJECT DRAWING FOR ACTUAL REQUIREMENTS
 2. DIMENSIONS INCLUDED ARE STANDARD
 3. STORAGE VOLUMES
TOTAL = 18790 LITRES
OIL STORAGE VOLUME = 2980 LITRES
SEDIMENT STORAGE VOLUME = 14.04 m³
 4. COMPONENT MASSES
TREATMENT CHAMBER BASE UNIT (INCL.SHAFT) = 12.1 TONNE
TREATMENT CHAMBER TOP UNIT (CONV. SLAB + SHAFT) = 11.2 TONNE
BYPASS CHAMBER = VARIES
 5. REFER TO BYPASS CHAMBER ASSEMBLY DRAWING FOR FIXING DETAILS FOR FIBREGLASS INSERT.
 6. BYPASS CHAMBER CONVERTER SLAB TO SUIT LOCAL ACCESS CHAMBER UNITS.
 7. FOR INLET AND OUTLET PIPE CONNECTION DETAILS REFER HC-BC52-A1 OR A2 AND KOR-N-SEAL INSTALLATION INSTRUCTIONS
 8. SWEETLIFT LIFTING ANCHORS PROVIDED FOR LIFTING ALL COMPONENTS (REFER PRODUCT DRAWINGS)
 9. NOTE MARKINGS - INLET AND OUTLET OVER EACH.
 10. JOINT SEALANT AS PER MANUFACTURERS RECOMMENDATIONS.
 11. OIL SAMPLE PORT AND DECANT PIPE TO BE VISIBLE AS PER PLAN VIEW.

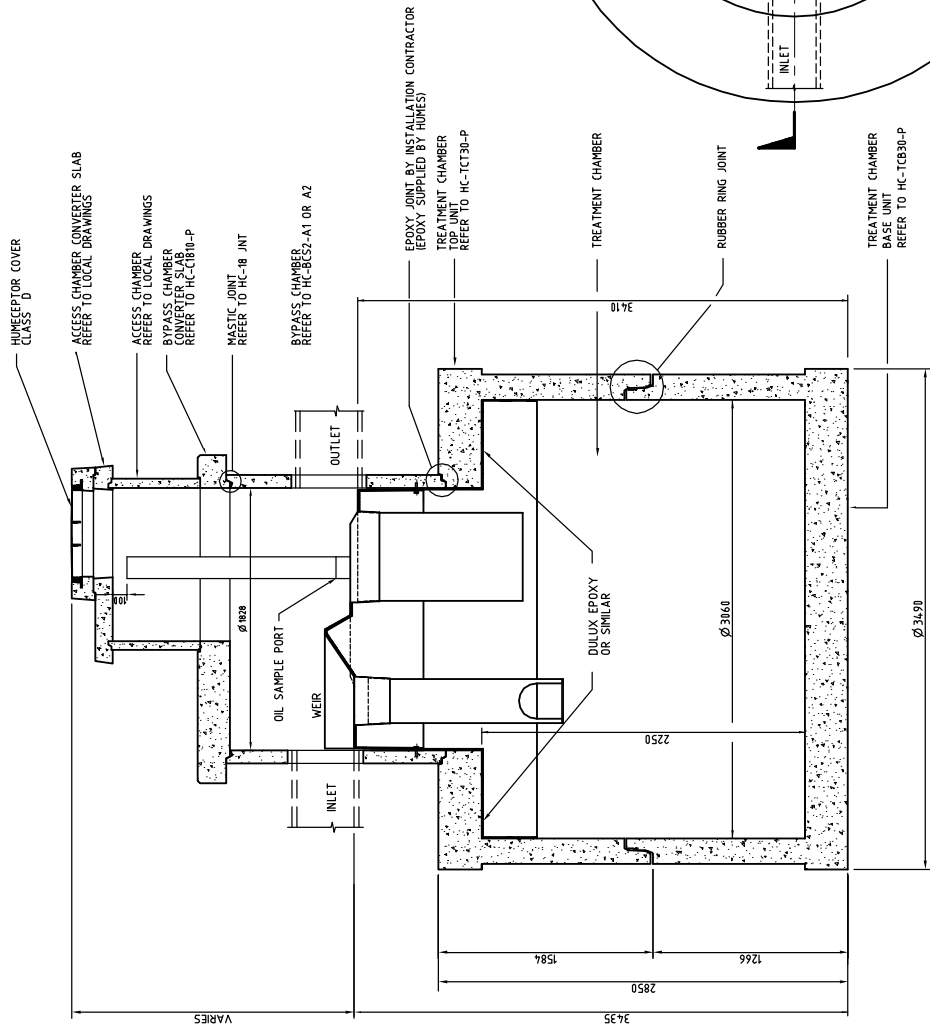

SECTION A-A
SCALE 1:25

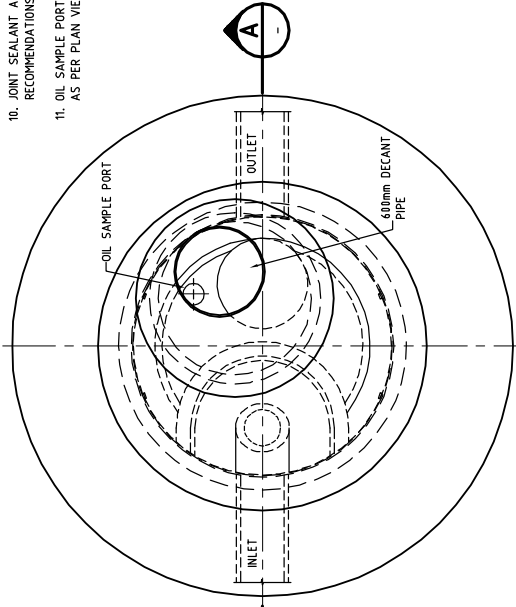

PLAN
SCALE 1:25

RUBBER RING SPECIFICATION

MATERIAL	: NITRILE
HARDNESS	: 43 ± 3 IRHD (AS1646)
PROFILE	: L25 (REFER Dwg. J1001-01)
ID	: 2775 ± 15mm

humes TECHNICAL (DESIGN) SERVICES
BRISBANE, QUEENSLAND

DFW	B-J	DFW	B-J
M.Z.	B-J	M.Z.	B-J
DFW	B-J	DFW	B-J
DFW	B-J	DFW	B-J

HUMCEPTOR™
STANDARD DRAWING
STC-18 HUMCEPTOR
ASSEMBLY DRAWING

PROJECT NO. **A2 HC-STC18-A**
SCALE 1:25

DATE 2003

Technical Drawings Pty Limited (ABN 61 191 732 297)
This drawing is the property of Technical Drawings Pty Limited and is subject to their intellectual property rights. It is not to be loaned, copied or reproduced in any form or by any means without permission of Technical Drawings Pty Limited.

ISSUE	DETAILS OF ALTERATIONS	DATE	BY	APP'D
0	UPDATED AND ISSUED FOR MANUFACTURE	13-10-18	M.Z.	DFW

NOTES:

1. TYPICAL ASSEMBLY DETAIL ONLY - REFER TO PROJECT DRAWING FOR ACTUAL REQUIREMENTS
2. DIMENSIONS INCLUDED ARE STANDARD
3. STORAGE VOLUMES
TOTAL = 2200 LITRES
OIL STORAGE VOLUME = 2900 LITRES
SEDIMENT STORAGE VOLUME = 18.45 m³
4. COMPONENT MASSES
TREATMENT CHAMBER BASE UNIT (INCL. SHAFT) = 11.2 TONNE
TREATMENT CHAMBER TOP UNIT (CONV. SLAB + SHAFT) = 10.1 TONNE
BYPASS CHAMBER = VARIES
TREATMENT CHAMBER SHAFT = 4.6 TONNES
5. REFER TO BYPASS CHAMBER ASSEMBLY DRAWING FOR FIXING DETAILS FOR FIBREGLASS INSERT.
6. BYPASS CHAMBER CONVERTER SLAB TO SUIT LOCAL ACCESS CHAMBER UNITS.
7. FOR INLET AND OUTLET PIPE CONNECTION DETAILS REFER HC-BCS2-A1 OR A2 AND KOB-N-SEAL INSTALLATION INSTRUCTIONS.
8. SWIFTLIFT LIFTING ANCHORS PROVIDED FOR LIFTING ALL COMPONENTS (REFER PRODUCT DRAWINGS)
9. NOTE MARKINGS - INLET AND OUTLET OVER EACH.
10. JOINT SEALANT AS PER MANUFACTURERS RECOMMENDATIONS.
11. OIL SAMPLE PORT AND DECANT PIPE TO BE VISIBLE AS PER PLAN VIEW.

RUBBER RING SPECIFICATION
 MATERIAL : NITRILE
 HARDNESS : 43 ± 3 IRHD (AS1616.6)
 PROFILE : L25
 ID : Z775 ± 16mm

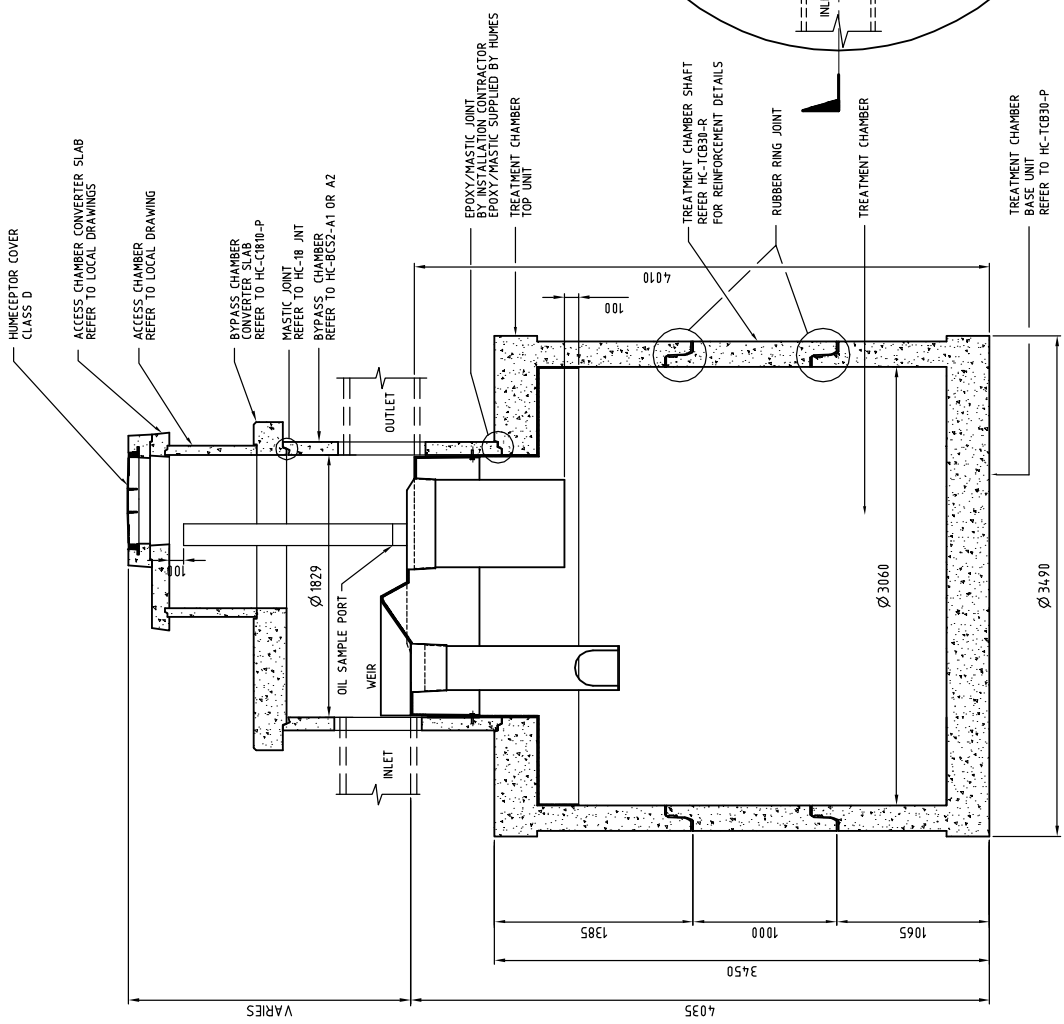
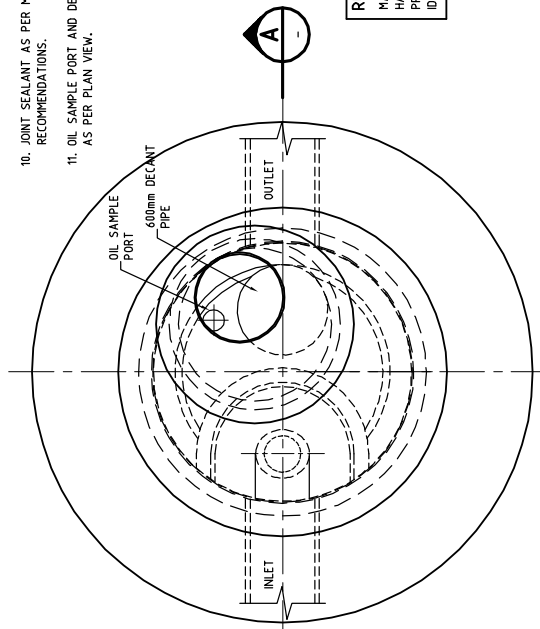

SECTION A-A
SCALE 1:25

PLAN
SCALE 1:25

HUMECEPTOR™
 STANDARD DRAWINGS
STC-23 HUMECEPTOR
 ASSEMBLY DRAWING

DATE	1:25
REV	A2
REV	HC-STC23-A
REV	0

Background Holdings Pty Limited (ABN 61 191 732 297)
 represents the design and construction of the property of Background Holdings Pty Limited and is subject to local laws and regulations. It must not be loaned, copied or communicated in any form or by any means without permission of Background Holdings Pty Limited.

ISSUE	DETAILS OF ALTERATIONS	DATE	BY	APP'D
0	UPDATED AND REISSUED FOR MANUFACTURE		RM	DFW

- NOTES:**
1. TYPICAL ASSEMBLY DETAIL ONLY - REFER TO PROJECT DRAWING FOR ACTUAL REQUIREMENTS.
 2. DIMENSIONS INCLUDED ARE STANDARD.
 3. STORAGE VOLUMES TOTAL = 29220 LITRES OIL STORAGE VOLUME = 4290 LITRES
SLURRY STORAGE VOLUME = 2350 m³
 4. COMPONENT PARTS: TREATMENT CHAMBER BASE UNIT (INCL. SHAFT) = 18.3 I
BYPASS CHAMBER CONVERTER SLAB (INCL. SHAFT) = 23.7 I
ACCESS CHAMBER CONVERTER SLAB (INCL. SHAFT) = 23.7 I
 5. BYPASS CHAMBER - VARIABES REFER TO BYPASS CHAMBER ASSEMBLY DRAWING FOR FIXING DETAILS FOR FIBREGLASS INSERT.
 6. BYPASS CHAMBER CONVERTER SLAB TO SUIT LOCAL ACCESS CHAMBER UNITS.
 7. FOR INLET AND OUTLET PIPE CONNECTION DETAILS REFER HC-BC52-A1 OR A2 AND KOR - N-SEAL INSTALLATION INSTRUCTIONS.
 8. SWIFTLIFT LIFTING ANCHORS PROVIDED FOR LIFTING ALL COMPONENTS (REFER PRODUCT DRAWINGS)
 9. NOTE MARKINGS - INLET AND OUTLET OVER EACH.
 10. JOINT SEALANT AS PER MANUFACTURERS RECOMMENDATIONS.
 11. VENT PIPE AND DECANT PIPE TO BE VISIBLE AS PER PLAN VIEW.

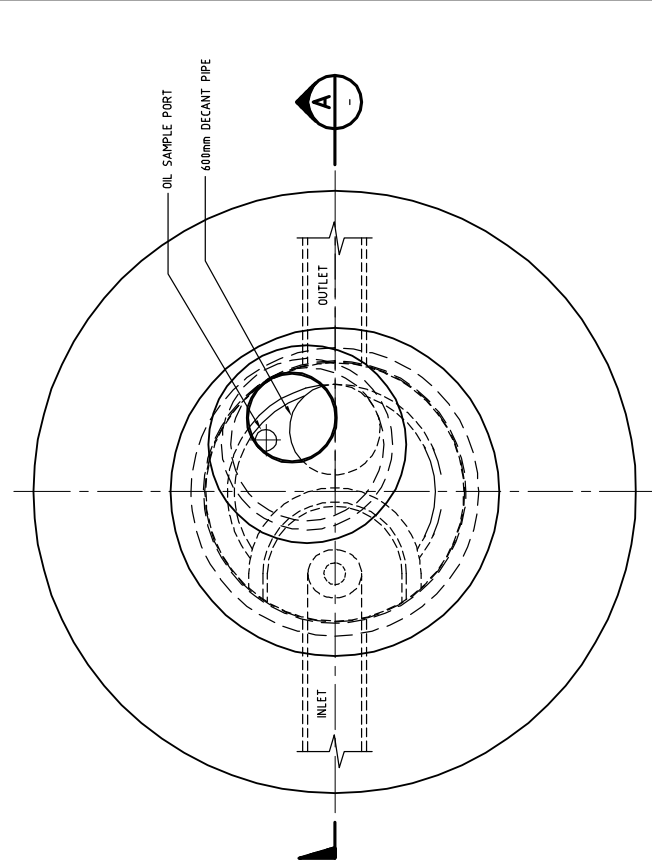

PLAN
SCALE 1:25

humes TECHNICAL (DESIGN) SERVICES
BRISBANE, QUEENSLAND

DATE	BY	APP'D	FOR
1/25	RM	DFW	ASSEMBLY DRAWING

PROJECT: **HC-STC27-A** 0

BACKFILLING PLY UNITS
 (AS 3775:2017)
 BACKFILLING PLY UNITS SHALL BE MANUFACTURED FROM POLYESTER FIBREGLASS FIBRE AND SHALL BE SUBJECT TO LOCAL REQUIREMENTS. IMMEDIATELY UPON REQUEST, IT MUST NOT BE TONED, COLORED OR COMMUNICATED IN ANY FORM OR BY ANY MEANS WITHOUT PERMISSION OF Humes Technical (Design) Pty Limited.

RUBBER RING JOINT SPECIFICATION
 MATERIAL : NITRILE
 HARDNESS : 43 (± 3) IRHD (ASTM D4015)
 PROFILE : L 38 (REFER DWG. J1002-01)
 ID : 34.0 ± 16mm

- IMPORTANT INSTALLATION INFORMATION**
1. FOUNDATION REQUIREMENTS - MIN. ALLOWABLE BEARING CAPACITY REQUIRED 200 kPa
 2. UNIT TO BE PLACED ON 150mm THICK BED ZONE MATERIAL IN ACCORDANCE WITH AS3775 REQUIREMENTS
 3. TREATMENT CHAMBER SHOULD BE FILLED WITH WATER TO 2/3 DEPTH IMMEDIATELY AFTER INSTALLATION (UNIT MAY FLOAT PRIOR TO BACKFILLING)

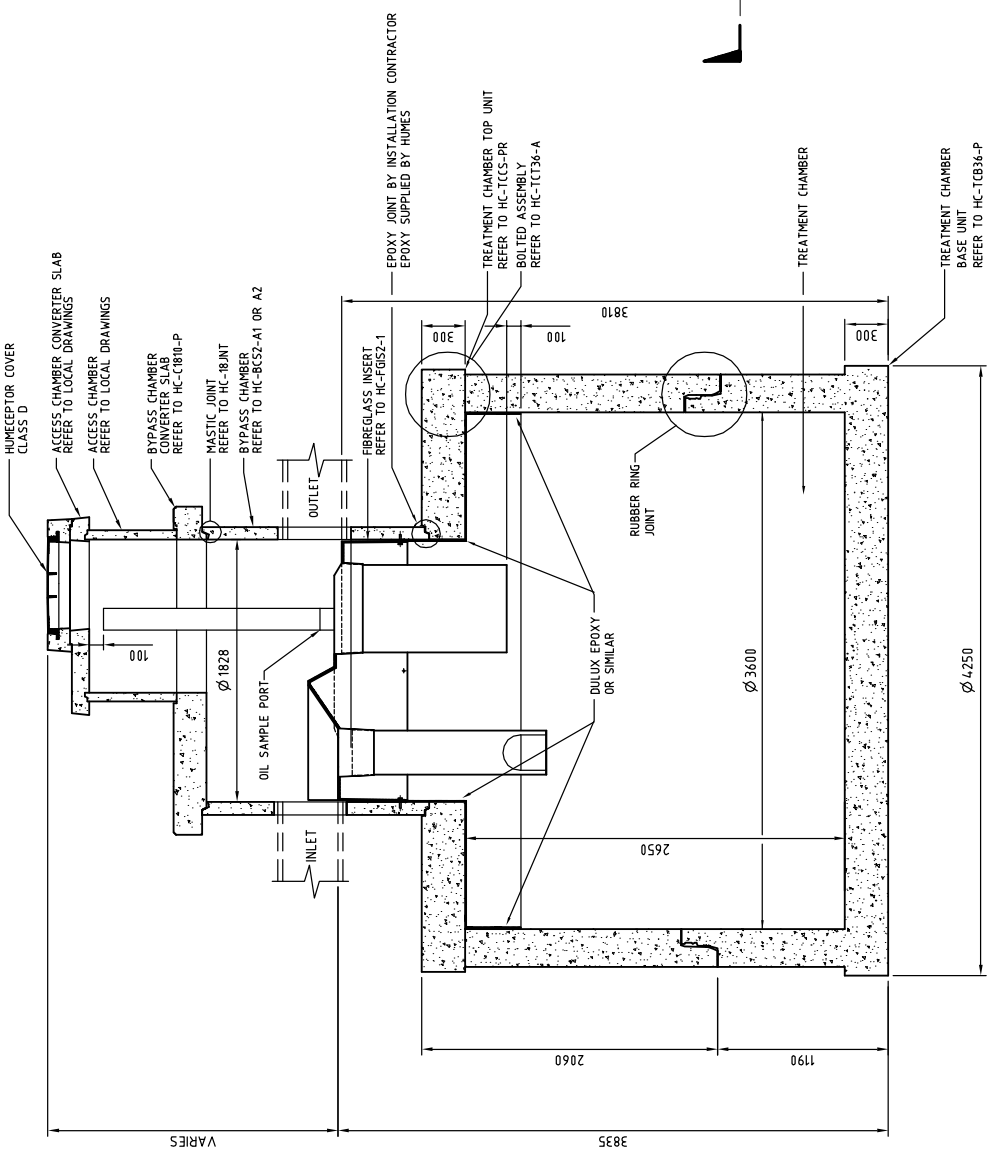

SECTION A-A
SCALE 1:25

FOR INFORMATION

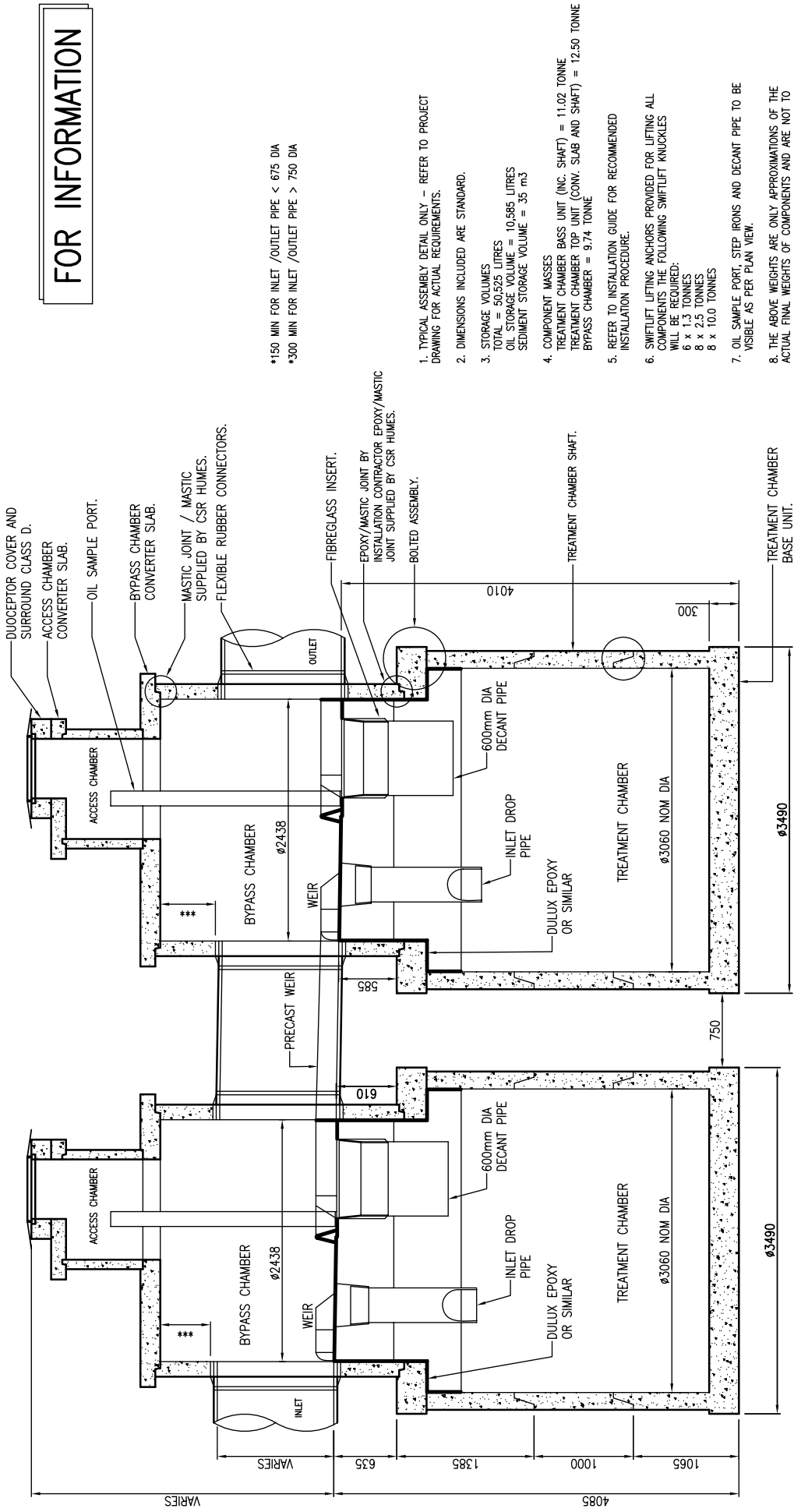

*150 MIN FOR INLET /OUTLET PIPE < 675 DIA
 *300 MIN FOR INLET /OUTLET PIPE > 750 DIA

1. TYPICAL ASSEMBLY DETAIL ONLY - REFER TO PROJECT DRAWING FOR ACTUAL REQUIREMENTS.

2. DIMENSIONS INCLUDED ARE STANDARD.

3. STORAGE VOLUMES
 TOTAL = 50,525 LITRES
 OIL STORAGE VOLUME = 10,565 LITRES
 SEDIMENT STORAGE VOLUME = 35 m³

4. COMPONENT MASSES
 TREATMENT CHAMBER BASS UNIT (INC. SHAFT) = 11.02 TONNE
 TREATMENT CHAMBER TOP UNIT (CONV. SLAB AND SHAFT) = 12.50 TONNE
 BYPASS CHAMBER = 9.74 TONNE

5. REFER TO INSTALLATION GUIDE FOR RECOMMENDED INSTALLATION PROCEDURE.

6. SWIFTLIFT LIFTING ANCHORS PROVIDED FOR LIFTING ALL COMPONENTS THE FOLLOWING SWIFTLIFT KNUCKLES WILL BE REQUIRED:
 6 x 1.3 TONNES
 8 x 2.5 TONNES
 8 x 10.0 TONNES

7. OIL SAMPLE PORT, STEP IRONS AND DECANT PIPE TO BE VISIBLE AS PER PLAN VIEW.

8. THE ABOVE WEIGHTS ARE ONLY APPROXIMATIONS OF THE ACTUAL FINAL WEIGHTS OF COMPONENTS AND ARE NOT TO BE USED.

NOT FOR CONSTRUCTION

		CLIENT:	N/A	REVISION		INITIAL	DATE
		CLIENT NAME:		A	ISSUE FOR CLIENT INFORMATION	JCM	25/10/07
JOB NAME:		DUOCEPTOR STC50					
DRAWING TITLE:		GENERAL ARRANGEMENT					
DRAWING NO:		BIS-DUO-002					
DESIGNED BY:		-		MODEL: STC60			
DRAWN BY:		JCM		25/10/07		SCALE: 1:40	
CHECKED BY:		CK		25/10/07		SIZE: A3	
						REV. A	

FOR INFORMATION

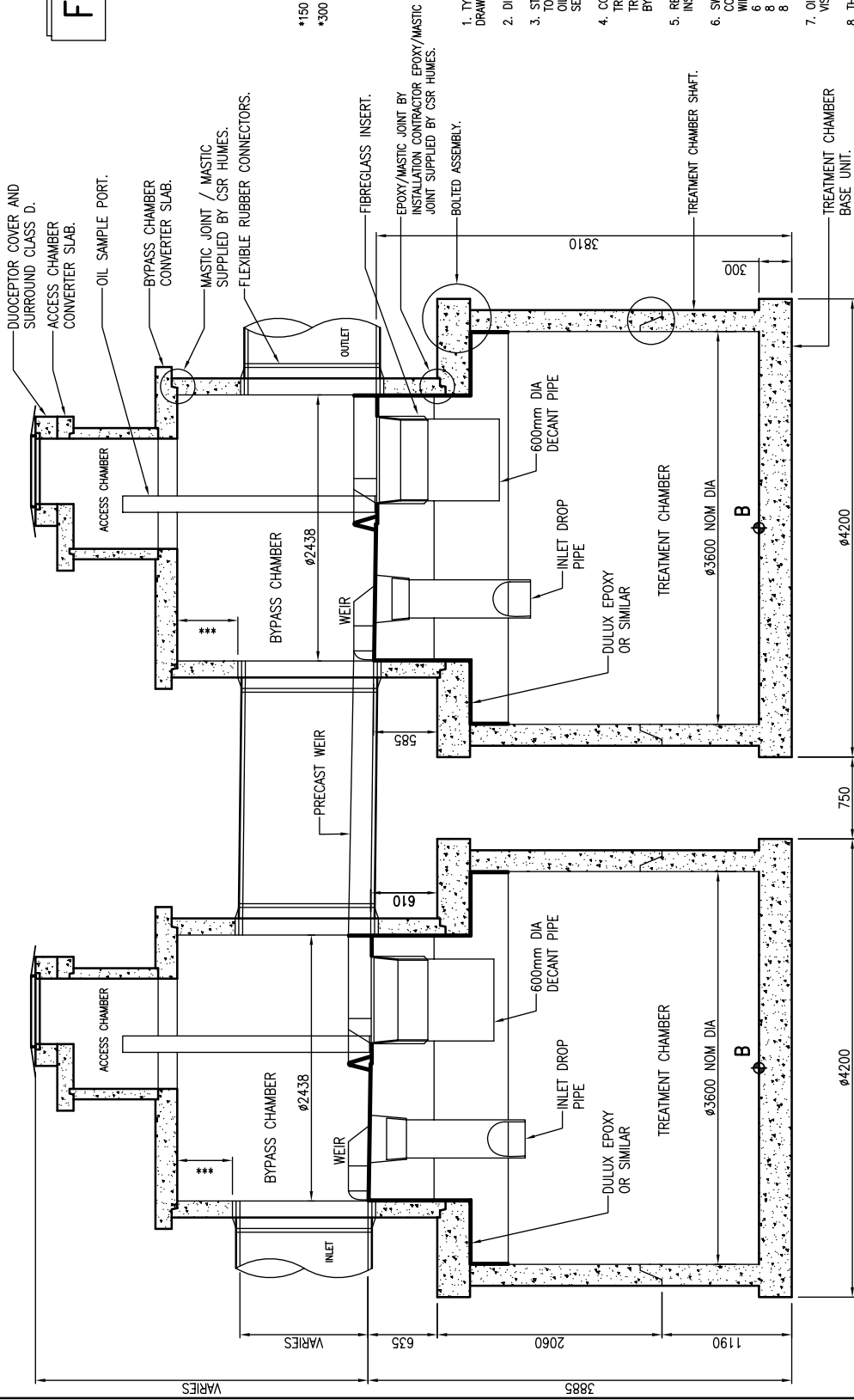

*150 MIN FOR INLET /OUTLET PIPE < 675 DIA
 *300 MIN FOR INLET /OUTLET PIPE > 750 DIA

1. TYPICAL ASSEMBLY DETAIL ONLY - REFER TO PROJECT DRAWING FOR ACTUAL REQUIREMENTS.
2. DIMENSIONS INCLUDED ARE STANDARD.
3. STORAGE VOLUMES
 TOTAL = 60,255 LITRES
 OIL STORAGE VOLUME = 11,560 LITRES
 SEDIMENT STORAGE VOLUME = 42 m³
4. COMPONENT MASSES
 TREATMENT CHAMBER BASS UNIT (INC. SHAFT) = 16.20 TONNE
 TREATMENT CHAMBER TOP UNIT (CONV. SLAB AND SHAFT) = 12.46 TONNE
 BYPASS CHAMBER = 9.74 TONNE
5. REFER TO INSTALLATION GUIDE FOR RECOMMENDED INSTALLATION PROCEDURE.
6. SWIFTLIFT LIFTING ANCHORS PROVIDED FOR LIFTING ALL COMPONENTS THE FOLLOWING SWIFTLIFT KNUCKLES WILL BE REQUIRED:
 6 x 1.3 TONNES
 8 x 2.5 TONNES
 8 x 10.0 TONNES
7. OIL SAMPLE PORT, STEP IRONS AND DECANT PIPE TO BE VISIBLE AS PER PLAN VIEW.
8. THE ABOVE WEIGHTS ARE ONLY APPROXIMATIONS OF THE ACTUAL FINAL WEIGHTS OF COMPONENTS AND ARE NOT TO BE USED.

NOT FOR CONSTRUCTION

CLIENT: N/A		JOB NAME: DOUCEPTOR STC60		GENERAL ARRANGEMENT	
CLIENT NAME:		DRAWING NO.: BIS-DUO-001		MODEL: STC60	
ISSUE:		DESIGNED BY: JCM		SCALE: 1:40	
REVISION:		DRAWN BY: CK		CHECKED BY: CK	
INITIAL:		DATE: 25/10/07		SIZE: A3	
DATE:		REVISION:		REV.: A	



Precast solutions

Top:
StormTrap® system

Middle:
RainVault® system

Bottom:
Segmental shaft

Stormwater

Stormwater treatment

Primary treatment

HumeGard® Gross Pollutant Trap

Secondary treatment

HumeCeptor® hydrodynamic separator

Detention and infiltration

StormTrap® system

Soakwells

Harvesting and reuse

RainVault® system

ReserVault® system

RainVault® Mini system

Precast concrete cubes

Segmental shafts

Stormwater drainage

Steel reinforced concrete pipes – trench

Steel reinforced concrete pipes – salt water cover

Steel reinforced concrete pipes – jacking

Box culverts

Uniculvert® modules

Headwalls

Stormwater pits

Access chambers/Manholes

Kerb inlet systems

Floodgates

Geosynthetics

Sewage transfer and storage

Bridge and platform

Tunnel and shaft

Walling

Potable water supply

Irrigation and rural

Traffic management

Cable and power management

Rail



Contact information

National sales 1300 361 601

humes.com.au

info@humes.com.au

Head Office

18 Little Cribb St
Milton QLD 4064
Ph: (07) 3364 2800
Fax: (07) 3364 2963

Queensland

Ipswich/Brisbane
Ph: (07) 3814 9000
Fax: (07) 3814 9014

Rockhampton
Ph: (07) 4924 7900
Fax: (07) 4924 7901

Townsville
Ph: (07) 4758 6000
Fax: (07) 4758 6001

New South Wales

Grafton
Ph: (02) 6644 7666
Fax: (02) 6644 7313

Newcastle
Ph: (02) 4032 6800
Fax: (02) 4032 6822

Sydney
Ph: (02) 9832 5555
Fax: (02) 9625 5200

Tamworth
Ph: (02) 6763 7300
Fax: (02) 6763 7301

Victoria

Echuca
Ph: (03) 5480 2371
Fax: (03) 5482 3090

Melbourne
Ph: (03) 9360 3888
Fax: (03) 9360 3887

South Australia

Adelaide
Ph: (08) 8168 4544
Fax: (08) 8168 4549

Western Australia

Gnangara
Ph: (08) 9302 8000
Fax: (08) 9309 1625

Perth
Ph: (08) 9351 6999
Fax: (08) 9351 6977

Northern Territory

Darwin
Ph: (08) 8984 1600
Fax: (08) 8984 1614



National sales 1300 361 601

humes.com.au

info@humes.com.au

A Division of Holcim Australia

This publication supersedes all previous literature on this subject. As the specifications and details contained in this publication may change please check with Humes Customer Service for confirmation of current issue. This publication provided general information only and is no substitute for professional engineering advice. No representations or warranty is made regarding the accuracy, completeness or relevance of the information provided. Users must make their own determination as to the suitability of this information for their specific circumstances. Humes accepts no liability for any loss or damage resulting from any reliance on the information provided in this publication. Humes is a registered business name and registered trademark of Holcim (Australia) Pty Ltd (Holcim). HumeCeptor is a registered trademark of Holcim. "Strength. Performance. Passion." is a trademark of Holcim. HumeCeptor is marketed, sold and manufactured by Humes under licence from Imbrium Systems Corp.

© April 2017 Holcim (Australia) Pty Ltd ABN 87 099 732 297. All rights reserved. This guide or any part of it may not be reproduced without prior written consent of Holcim.