

Two piece arches Installation guide

January 2022



Contents

| | |
|---|-----------|
| Introduction | 2 |
| Recommendations | 2 |
| Humes site representative | 3 |
| In-situ footings | 3 |
| Reinforcement and concrete | 3 |
| General construction procedure | 3 |
| Excavation | 3 |
| Footings | 4 |
| Levelling pads, shims and shim blocks | 4 |
| Tolerances and critical dimensions | 5 |
| Scour protection | 5 |
| Drainage | 6 |
| Handling of precast arch system elements | 7 |
| General | 7 |
| Storage and transportation | 8 |
| Arch elements | 8 |
| Spandrel and wingwalls | 8 |
| Erection of precast elements – Arches | 9 |
| Lifting equipment – Cranes | 9 |
| Erection of the arch units | 9 |
| Arch-to-arch tie rod fixing | 12 |
| Placing second and following arches | 13 |
| Erection of precast elements – Spandrel | 14 |
| General | 14 |
| Erection of spandrels | 18 |
| Alternative installation method | 20 |
| Erection of precast elements – Wingwalls | 21 |
| Grouting, sealing and in-situ concrete | 23 |
| Grouting | 23 |
| Top arch in-situ joint | 24 |
| Other in-situ concrete | 25 |
| Sealing of joints | 25 |
| Backfilling | 26 |
| General | 26 |
| Backfill material specifications | 27 |
| Zone A | 27 |
| Zone B | 27 |
| Zone C | 28 |
| Zone D | 28 |
| Embedment materials placement | 29 |
| Backfill compaction | 30 |
| Restrictions for construction machinery | 31 |
| Appendices | 32 |
| Contact information | 39 |

Introduction

This guide outlines the construction procedures and specifications required for the trouble free installation of the two piece concrete arch system.* Humes two piece arch systems have an in-situ concrete joint at the external apex of the arch (profiles are shown in Appendix 1, page 30).

Prior to commencement of any project, all supervisory personnel should carefully review this guide. Reference should be also made to the Humes two piece arch system general assembly standard drawings for typical installation requirements or project specific drawings for general assembly prepared by Humes engineers. Note that Humes drawings are system assembly drawings and do not constitute a site general layout which is provided for and specified in the owners consulting engineers project documents.

This guide should be read in conjunction with the specific project contract documents. Where the contents of this guide differ from the contract documents, the requirements of the contract documents will govern. Supervisory personnel should however consult with Humes engineers where differences between the project contract documents and this guide are identified.

The information presented in this guide is for general construction purposes only. Applications of the two-piece arch systems and the specific data for each installation must be evaluated by the owner or their consulting engineer to determine site suitability, possible site access problems for plant, and other constructability issues.

In the event of any conflict between information in the guide and local legislative requirements, that legislative requirements shall take precedence. Statements in this guide are not to be construed as either guarantees or implied warranties. Satisfactory adherence to this guide will not discharge the contractor from the contractual requirements of the project.

*This guide is not relevant to the installation of the one-piece and 3-Pin arch systems. Separate handling and installation guides should be referred to for these types of systems which Humes can supply copies of these documents on request.



Recommendations

The main contractor/erection contractor should produce a safe work method statement specifically for the erection of the arch structure.

In the planning stages for the footings and erection a Sample Shopping List (Appendix 2, page 31) should be prepared and then amended to project specific at a pre erection meeting held on site one to two weeks prior to erection.

This meeting should be attended by main contractor/erection Contractor, crane company and Humes to discuss shopping list, safe work method statement and carry out site inspection.

Humes site representative

A Humes representative can be made available to assist with pre-planning the delivery and erection process. Subject to availability on a project-by-project basis and on the days requested, a Humes representative may also attend the construction site during the installation but will act as an observer only.

Unloading, installation and erection of the two piece arch system is the sole responsibility and at the sole risk of the contractor, including as to quality of those works. Humes and its Representatives(s) are not obliged to provide any advice to the contractor and is not responsible for compliance of the site or contractor with any contractual documentation or project requirements. Reliance on any advice given or comments made by Humes Representative is at the sole risk of the contractor.



Left: Humes site representative observing installation

In-situ footings

Reinforcement and concrete

- Reinforcement should conform to AS 4671.
- Concrete should be a minimum grade N50 to AS 1379.
- Cover to reinforcement for all in-situ work shall be in accordance with AS 3600 Concrete Structures or AS 5100 Bridge Design as appropriate.
- All grout for arch keyway and wingwall dowel holes should be 50 MPa:
 - Minimum cement content: 500 kg/m³.
 - Maximum aggregate size: 7 mm.
 - Maximum drying shrinkage: 400 microstrain when tested to AS1012.13
- Alternatively maximum drying shrinkage: 600 microstrain when tested to AS1012.13 in combination with a waterproofing membrane (similar to that used at arch joints) applied across the outside face surface of the arch to keyway connection (Refer to Figure 1).
- Alternatively use bagged proprietary grout.

General construction procedure

Excavation

Prior to any excavation work, all underground service conduits must be located and precautions taken to protect them.

The systems in-situ footings are typically shallow strip footings with supporting piers or piles spaced along its length. Deep excavations for in-situ footings are not common however where these occur care should be taken.

It is recommended that a suitably qualified geotechnical engineer inspects the open excavation and that any discrepancies between soil properties and those assumed in the design are reported to the superintendent for evaluation.

Top:
Typical footings
with shim blocks in
place.

Footings

Construction of the in-situ footings for arches and spandrels should be in accordance with the owners consultant engineers contract documents.

Wingwall footing preparation should be in accordance to that recommended on the Humes General Arrangement (GA) drawings.

Normally the wing walls sit on materials with specifications to that shown on the Humes drawings with a blinding layer of 100 - 150 mm thick to set the leveling packers on.

Levelling pads, shims and shim blocks

To ensure that arch units are laid on a level foundation and uniformly supported along the unit length, a 50 mm nominal allowance is provided between the underside of arch base and the level of the base of the footing keyway for a 400 mm long 50 MPa grout pad or the placing of compressed fibre cement sheeting packers 400 mm x 300 mm (see Appendix 2) supplied by the installation contractor.

Width and depth of keyway also provides an allowance for precast shim blocks (supplied by Humes) which are placed at the same RL or up to 10 mm lower than that of the 400 mm x 300 mm levelling pads (paving bricks, compressed fibre cement sheeting or hard PVC plastic shims can be used to support the shim blocks at the required level).



Tolerances and critical dimension

All in-situ work should generally be in accordance with the requirements of AS 3600 Concrete Structures or AS 5100 Bridge Design as appropriate for quality of workmanship and materials and for tolerances on design dimensions and reinforcement placement.

In addition to these general requirements and to ensure a trouble free installation with erection time kept to a minimum, special care should be taken in forming three critical areas in the arch foundation. These areas are:

1. the horizontal alignment of the arch keyway
2. the level of the arch keyway
3. the critical dimension to the span control points.

Figure 1 shows the critical dimension location and the actual dimensions for each size arch are shown on the Humes GA drawings.

Scour protection

In most instances where the arch structure is exposed to scouring either during the construction period or in finished operation it is essential that the works be protected.

In particular where in-situ footings are designed and specified as strip footings without supporting piers or piles it is critical for the systems structural stability that the integrity of the footing foundation be protected against degradation from the effects of surface water flows.

The final surface treatments for scour protection to in-situ footings and bed of stream are specified by the site layout design in the owners consultant engineers contract documents.

Figure 1 – Critical dimension and control points

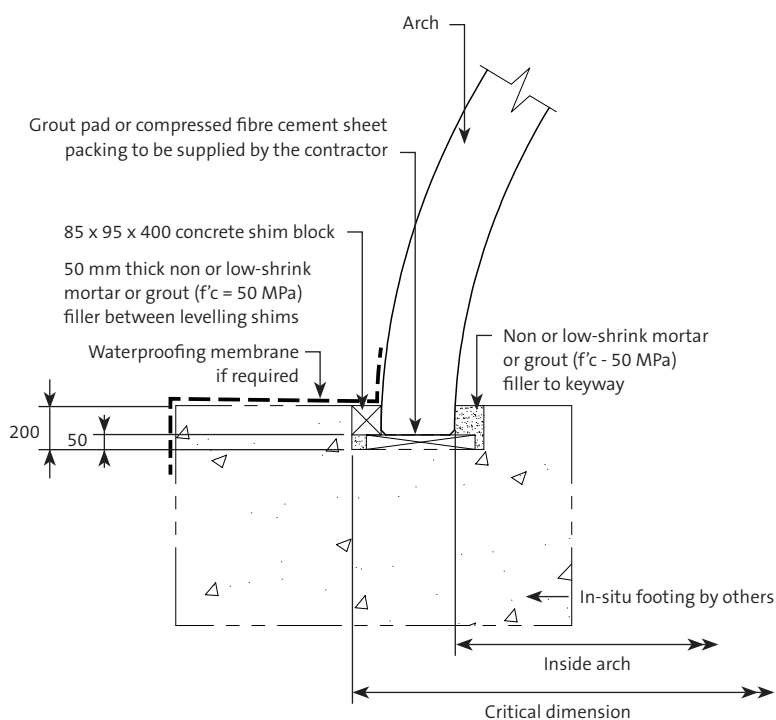

Drainage

The design of the two piece arch system makes no allowance for hydrostatic pressure due to entrapped ground water. It is therefore an essential part of the design that the structure be adequately drained.

Since all element joints within the systems are unsealed butt joints, the free release of ground water occurs at the structure/soil interface. In instances where it is necessary to prevent ingress of water into the arch structure the joints between elements will need to be sealed to prevent water flows and for these cases it is essential that the design include soil drains in the backfill.

Where the arch structure is located within a tidal zone or within a frequently rising and falling water table, the Zone B backfill material must be enclosed within a suitable filter fabric to eliminate the movement of fines either into or from the placed and compacted Zone B material.

Consideration should also be given to the provision of weep holes in the arch units which should also be covered with filter fabric to prevent loss of fines material.

When the two piece arch system is used on an incline provision should be made to allow water to be directed away from the structure.

Note that the arch structure is designed to act as a soil/structure model. The specified quality and compaction of the backfill surrounding the arch can be adversely affected by groundwater flows and with some materials their supporting strength can be lost in the presence of excess soil water. As a minimum requirement, the suggested drainage lines are shown in Figure 2 below.

The owner's consultant engineer shall be responsible for design of adequate drainage to suit the site conditions.

Figure 2 – Suggested drainage lines

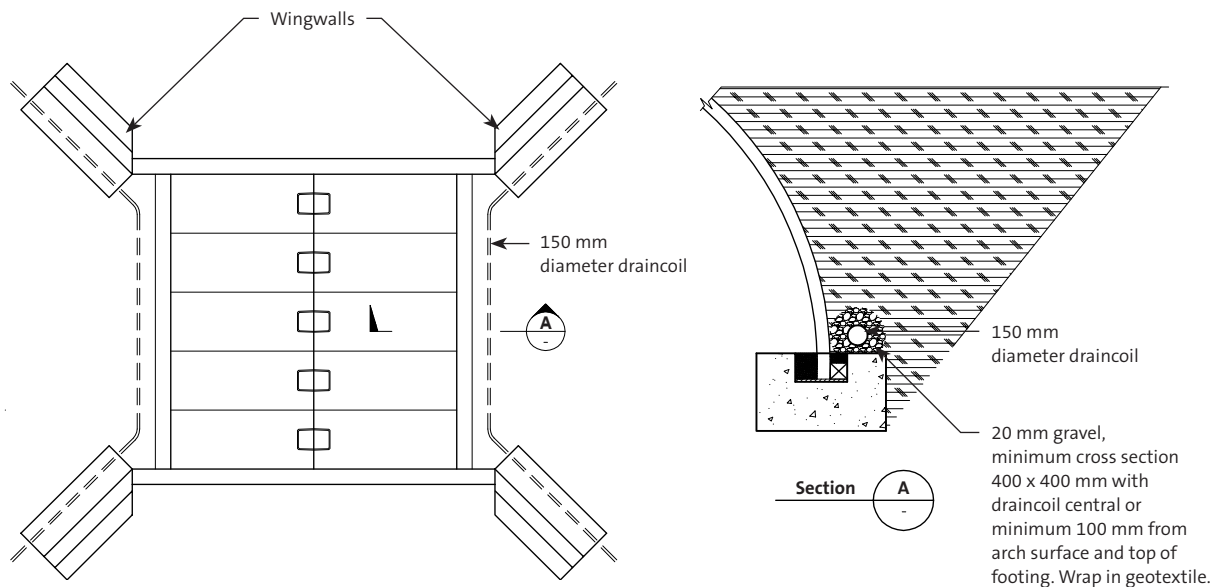

Handling of precast arch system elements

General

Wherever possible, all system elements should be lifted from the delivery truck, rotated in mid air and set directly onto the prepared footings. However, if circumstances are such that temporary site (or near site) storage of arch units is necessary, ensure that arch units are stored in the “as delivered” position on hardwood timber pads and on level compacted ground.

The location and number of these pads around the arch perimeter must be as shown in Figure 3. All precast units are supplied with cast in lift anchors for handling. To ensure that the units are not over stressed resulting in possible concrete cracking, all units must be handled using the cast-in lifting anchors fitted with lifting clutches.

Lifting clutches can be arranged through the crane contractor or the supplier and it is the installation contractor’s responsibility to ensure that they are available on site.



Storage and transportation

Arch elements

Store and transport only in the vertical position, i.e., perpendicular to the final position, as shown in Figure 3 below.

Figure 3 – Storage and transportation

Storage:

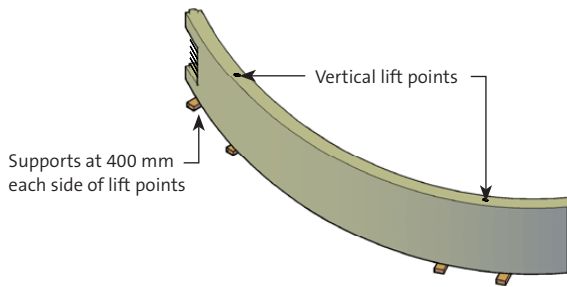

Transportation:

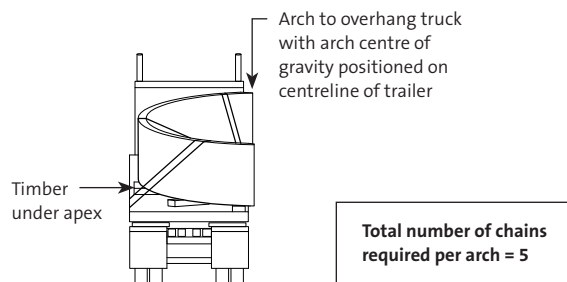
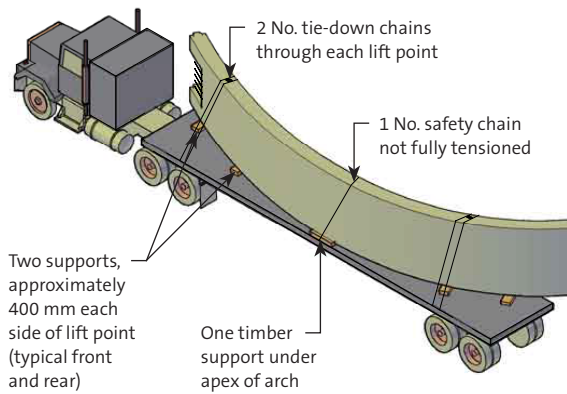

Spandrel and wingwalls

Both spandrels and wingwalls are transported horizontally except for small wingwalls which may travel upright as shown in Figures 4 and 5 respectively.

Figure 4 – Spandrel transportation

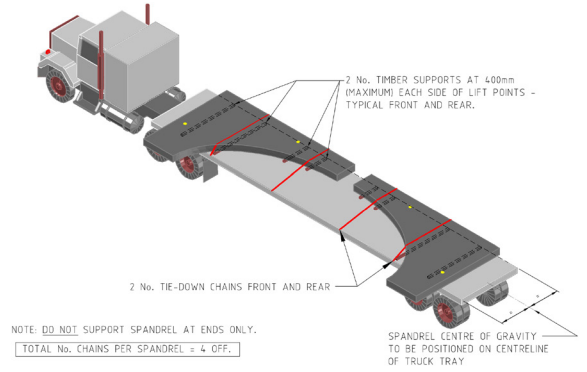
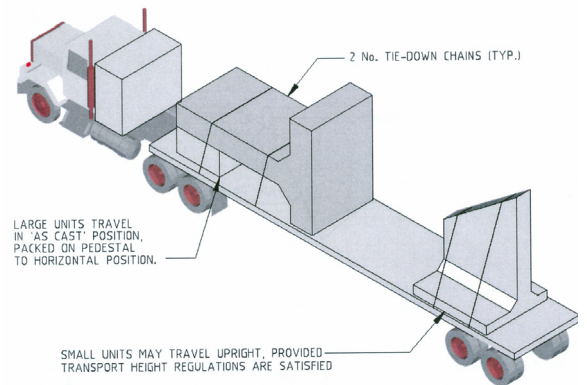

Figure 5 – Wingwall transportation



Erection of precast elements – Arches

Lifting equipment – Cranes

The contractor is to supply all erection tackle and cables as outlined in the sample shopping list (Appendix 2 on page 34) necessary to install the two-piece arch system elements. It is necessary when erecting the two-piece arch system that two cranes must be used and be capable of individually lifting each unit and turning them into the erecting position.

It is the responsibility of the contractor to ensure that the correct lifting capacity cranes are available to handle each precast unit. Field conditions should be checked and overhead power lines located well in advance to ensure proper crane location and to avoid any lifting restrictions.



Top:
Arch units being lifted into position using two cranes

Erection of the arch units

It is recommended that all surveying, bridge set out and placement of leveling pads for arches, spandrel and wingwalls is completed prior to erection day. Concrete shim blocks are 85 mm wide x 95 mm thick and 400 mm long. These will be supplied with all Humes arch systems and are used to prevent lateral spreading of the arches at the base supports after being placed (see Appendix 4 for diagram showing shim block installation, page 38).

Measure the actual length of one of the arch footings and then calculate the distance between centres of the arch joints allowing for the end arch units to start flush with the ends of the footing and nominal 20 mm gaps between the arch units. Then measure from one end of the arch footing to the first joint centreline and mark this on the top outside rear face of the arch footing. Then continue to mark out the subsequent joint centrelines along the length of the footing. Repeat this procedure for the other arch footing. The 400 mm long grout levelling pads or compressed fibre cement sheet levelling pads are then installed at the marked out joint centrelines for each arch footing.

Leveling packers are cut from compressed fibre cement sheeting material available from most hardware stores in many sizes e.g. 19 mm, 15 mm, and 12 mm thick. A set of leveling packers is 400 x 300 x 50 mm high, e.g. 2 x 19 mm and 1 x 12 mm = 50 mm. They are used under the arches, spandrels and wingwalls. The sets of leveling packers are first set up and leveled in the base of the arch footing keyway on both side one and side two of the bridge footings on the centerline of joint between the arches. At the centerline joint each arch will share half the leveling packer (i.e. 200 mm) and the end arches will start with a full set of 400 x 300 x 50 mm leveling packer.

Set up side one by placing a shim block 95 mm away from the outside vertical face at each end of the footing on the already levelled 400 mm x 300 mm packers. The shim blocks are located on the leveling packers with each arch sharing half a shim block.

Stretch a stringline the length of the footing across the front vertical face of the shim blocks in the arch keyway and align all the internal shim blocks to the stringline at their respective positions and fine tuning with hard PVC (150 mm x 100 mm) packers if required. This line will mark the arch outside span for one side of the footing.

Top:
Shim blocks and
levelling pads in
place – completed
setup marked
with paint

Bottom:
An example of
correct apex arch
jointing

Carry out the same procedure on the opposite side footing (side two) but first set the two end shim blocks at the specified arch outside dimension shown on the drawings before string lining along the footing. If necessary the shim blocks can be rotated and again shimmed with additional hard PVC packers to align the face.

The shim blocks on side two can either be located in the same position as side one at the joint centrelines or alternatively can be located at the centre of the arch and supported on separate compressed fibre cement sheet packers, hard PVC packers (150 mm x 100 mm) or paving blocks (maximum height 40 mm). Refer to Appendix 4 on page 38.

Prior to commencing lifting and rotation of the arch units for erection, ensure that;

- a) the stirrups required for the top arch in-situ joint are positioned and bunched up over the starter bars cast into arch in-situ joint void (refer to first photo on page 24) otherwise they will be very difficult to install once the arch units have been erected, and
- b) ensure any brackets required for spandrel tieback assemblies are bolted to the end arch units.

Attach sling assemblies as shown in Figure 6 using lifting clutches engaged with the lifting anchors cast into the arch unit. Initially lift the arch unit vertically using the edge lifters and auxiliary hook to provide sufficient clearance above the ground for mid air rotation. Then begin lifting the main hook to gradually bring the arch to the rotated position as shown in Figure 7, with the arch weight completely transferred to the main hook.

With the arch in the rotated position, disconnect the auxiliary hook slings by disengaging the lifting clutches from the edge lifters. This should be done using an EWP where necessary.

Note that where use of a single crane which has both main and auxiliary hooks is not possible, the role of the auxiliary hook can be replaced by using a suitable separate crane.

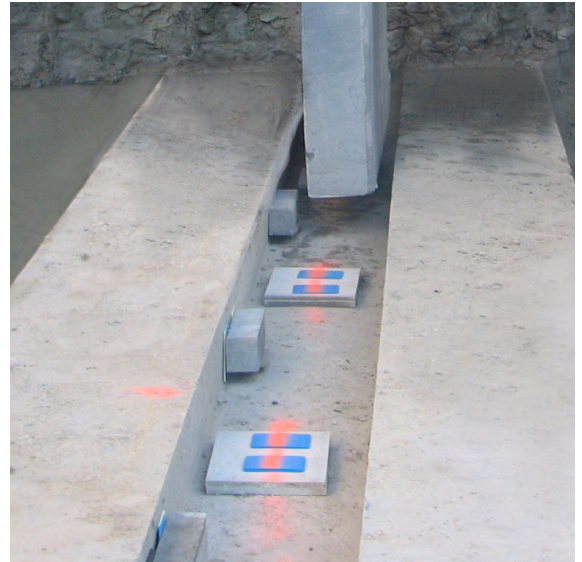
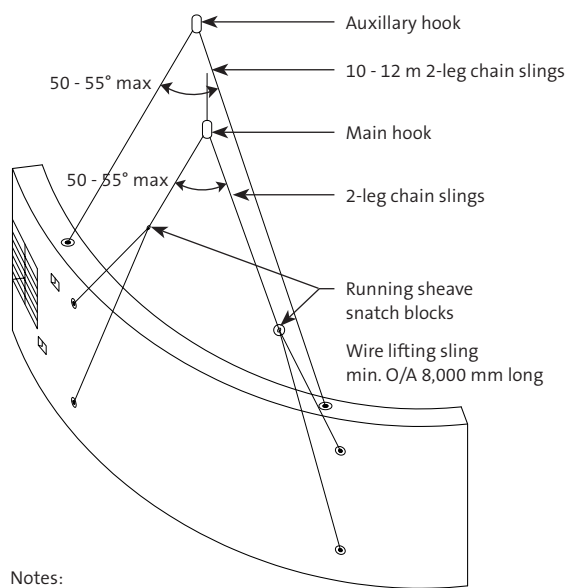

Figure 6 – Arch element lifting sling connection



Notes:
Sling lengths calculated at
50-55 degrees + 1,500 mm

Snatch block slings to be min.
O/A 8,000 mm in length

Figure 7 – Rotated arch unit

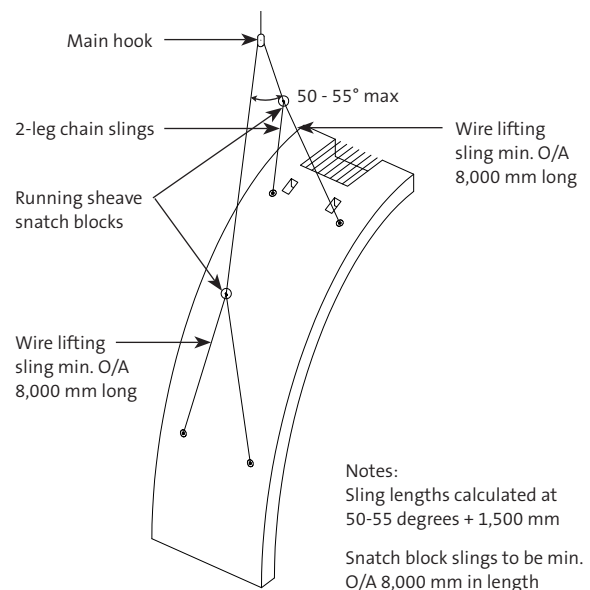

Notes:
Sling lengths calculated at
50-55 degrees + 1,500 mm

Snatch block slings to be min.
O/A 8,000 mm in length

Each crane then places its half arch onto the leveling packers, hard up against the vertical face of the shim block and then positioned relative to the joint centerline marked on the back face of the keyway. Before lowering the half arches to the jointing position, softwood timber wedges are placed by hand opposite the shim block against the inner arch face and inner face of the arch footing keyway and lightly secured to hold the arches firmly against the shim block and in position during the jointing procedure. Then lower the arches until the gap between the arches at the top is approximately 250 mm to 300 mm.

Using a suitable EWP, an operator gains access to the apex arch joint and guides the continued gradual lowering of the two half arch units so that they come together with correct alignment over the full length of the apex arch joint. For correct alignment, the vertical faces of the male and female tongue and groove joint come together to mate as a vertical concrete to concrete joint with even bearing over the contact surface.

Ensuring the correct alignment and mating of the arch apex joint on the first arch erected is critical.

Note that in order to ensure correct mating at the arch apex joint, it may be necessary to adjust the arch span of the first arch erected by use of suitable shims (compressed fibre cement sheets and/or hard PVC shims) placed between the concrete shim blocks and the outer vertical face of the in-situ footing keyway. If this is necessary, all subsequent arches are then installed at the same adjusted span.

Arch-to-arch tie rod fixing

Before dropping off the full weight of the arches check the joint alignment. When alignment has taken place lose weight equally from both cranes down to zero tonnes and before unhooking the units check the units for plumb. When the units have been plumbed and before releasing the crane the first arch must have the two arch-to-arch rods fitted into the holes located in the top of arch in-situ joint keyway and lightly tightened with a ring spanner (see Figure 8).

The tie rod fixing procedure is as follows. Two tie rods are fitted to each of the first two arch spans erected and lightly tensioned with a ring spanner. One tie rod from the second arch span is removed and fitted to the third arch span once erected. The remaining tie rod from the second arch span is removed and fitted to the fourth arch span once erected. The tie rod from the third arch span is then removed and fitted to the fifth arch span once erected.

This process is continued until the end of the day and/ or until the final arch span is erected, with two tie bars fitted to the final arch span. The two tie bars in the first and last arch spans remain permanently in the arch structure.

This process is typically shown on the Humes project drawings, however, note that in some instances, two tie bars may be required to remain in place permanently in each arch span.



Top:
Checking plumb
before unhooking
crane

Figure 8 – Arch-to-arch tie rod detail

Erection tie bar supplied by Humes torqued to 300 Nm nominally (being the resultant torque when applied by an average size man using a medium degree of effort)

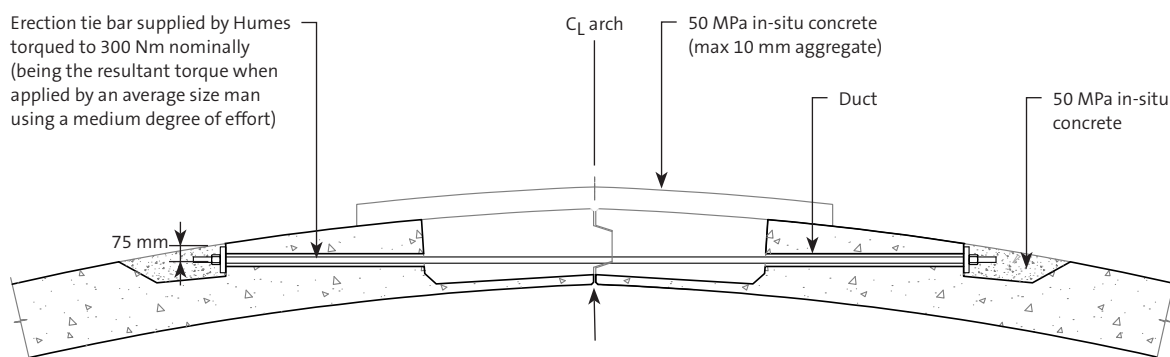

Joints to be covered with a 250 mm wide strip of adhesive mastic (supplied by others), backed on one side with a durable synthetic laminate. Concrete surfaces to be primed prior to placing tape in accordance with the manufacturer's instructions.

Placing second and following arches

Top:
Standard second
arch and special
end arch unit

Middle:
Placing second arch

Bottom:
Use of packers to
accurately space
arches

Once the first arch span has been erected, plumbed, the apex joint checked for correct alignment and the tie rods installed, the second and subsequent arch spans are erected using the same procedure for lifting, rotating and positioning as the first arch span.

Note that it is important to work within the joint centrelines marked out on the arch footings to avoid creep and ensure even joints are achieved over the length of the arch structure.

The nominal joint gap between arch spans is 20 mm (minimum 10 mm, maximum 30 mm), however this may vary slightly depending on the actual overall footing length and any minor variations in the lengths of the precast arch units. It is helpful to have available a range of 5-20mm thick hard PVC shims to assist in spacing the arch units as they are being positioned between the marked joint centrelines.

The second and subsequent arch spans should be placed such that a concrete off form end is adjacent to a hand finished concrete end with edge lifters, except for external arch units where the orientation of ends may be controlled by cast-in arch to spandrel tie back fittings assemblies.

When erecting the second and subsequent arch spans, at the point where the two half arches are in the position such that the gap between arches at the apex is approximately 250 - 300 mm, an operator on top of the arches wearing a safety harness, places a tee wedge (listed in Appendix 2 - Shopping List) against one half arch to hold the unit at the required joint gap at the apex of the arch. The operator uses a birk bar to gently guide the other half arch down so that they come together correctly aligned over the full length of the apex arch joint.

Note that where end treatments are used, the arch units at the ends of the structure (and sometimes additional arch units near the ends of the structure) will differ from the internal arch units. These arch units typically have cast in ferrules for the arch to spandrel tieback assembly connections. Refer to the Humes project drawings for positioning of the various arch types.



Erection of precast elements – Spandrel

General

The spandrel for the two piece arch system consists of four pieces. There are two sets of lower and upper spandrel segments, one for each side of the arch. Refer to Figure 12.

The spandrels are fixed to the special end arch unit (or units) using the permanent installation tieback assemblies provided.

Due to the geometry of the spandrels, temporary installation brackets are used to maintain them in the installed position by allowing the weight of the spandrels to be partially supported on the outer surface of the end arch. Refer to Figure 9 for typical Temporary Installation Bracket assembly detail.



Left:
Temporary
installation bracket
fixed into special
end arch unit

Figure 9 – Temporary installation bracket assembly

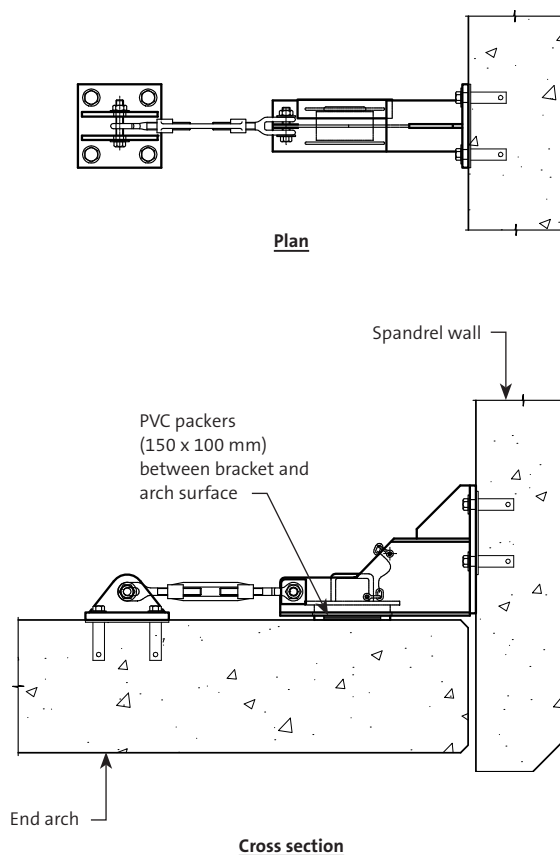

Right:
Lower and
upper spandrels
supported with
temporary
bracing prop

Where the outer edges of the spandrels are to be supported by concrete wingwalls, temporary adjustable props are attached to the rear face of the spandrels and anchored back down to the arch footing in order to provide temporary support during installation and to help align them until they are fully supported by the wingwalls and backfilling. Where the outer edges of the spandrels are not supported by concrete wingwalls or there are other site specific restrictions, the temporary adjustable props may be attached to the front face of the spandrels (rather than the rear face) and anchored back down to suitable concrete blocks or may also be anchored between the rear face of the spandrels back down to the arch units rather than the arch footing.

The spandrels are typically supplied with nominal cast in ferrules for attaching the temporary adjustable props on site, however, it should be noted that the installation contractor is responsible for the design of the temporary propping system for the spandrels to suit the site conditions and the available propping equipment. Also note that if required by the propping design, suitable alternative mechanical anchors may be drilled into the spandrels and/or arch units for the purpose of attaching the temporary adjustable props.

The permanent arch to spandrel tieback assemblies comprise of brackets fixed to both the arches and spandrels, two tie bars - one with left hand and one with right hand thread and a connecting turnbuckle. The tie bars are normally marked or colour coded and



all the tie bars of one hand (i.e. either left hand or right hand) should be fitted to the arch brackets prior to commencement of the spandrel erection. This will ensure that rotation of each turnbuckle in one direction (i.e. either clockwise or anticlockwise) will result in the same adjustment action for each tieback assembly (i.e. either shortening or lengthening). As the spandrels are erected, the tieback assemblies are installed and adjusted over the arch to spandrel interface.

Spandrel tieback assemblies are supplied galvanised and are required to be wrapped on site with corrosion protection tape supplied by the installation contractor. Care should be taken to ensure that the tape is not damaged during backfill placement and compaction. The area around the tieback assemblies is then filled with sand or similar and then packed with a dry mix in-situ concrete surround to protect them during backfill. Refer to Figure 10 below.

Figure 10 – Permanent tieback assemblies

All tiebacks are to be galvanised and wrapped with denso tape supplied by installation contractor

Areas around tieback assemblies to be filled with sand or similar

100 mm min packed dry mix in-situ mortar surround for protection during backfill supplied by installation contractor

Joints to be covered with a backing rod and 250 mm wide strip of adhesive mastic (supplied by others), backed on one side with a durable synthetic laminate. Concrete surfaces to be primed prior to placing tape in accordance with the manufacturer's instructions

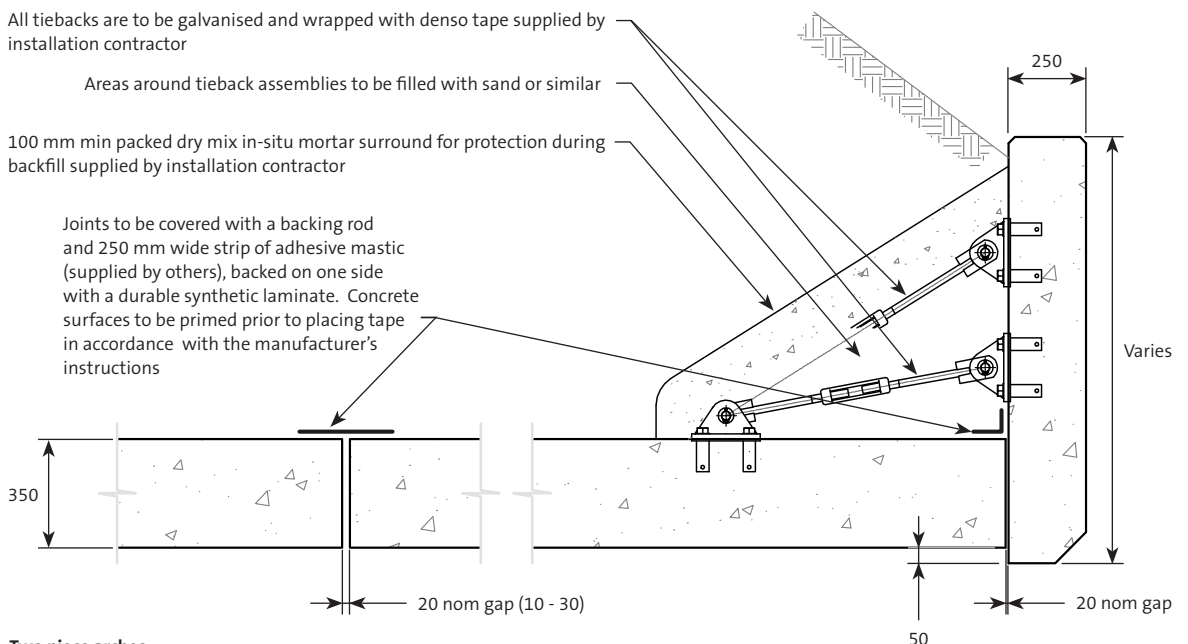

In some cases, particularly where the outer edges of the spandrels are not supported by concrete wingwalls, a permanent propping system may be required to support the spandrels. Refer to Figure 11(a).

Alternatively, where the length of the arch structure is relatively short, the use of similar permanent tie bars connecting the spandrels at each end of the arch structure may be used. Refer to Figure 11(b).

Figure 11 (a) – Permanent propping system

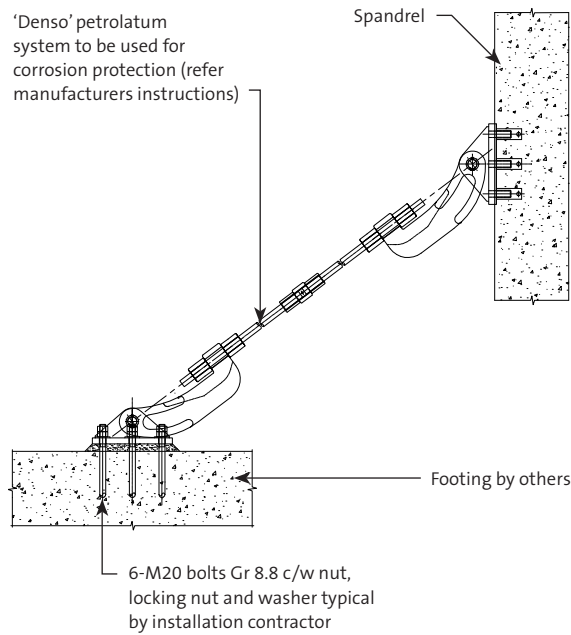

Top:
Spandrel connection

Middle:
Footing connection

Bottom:
Props in place



Figure 11 (b) – Permanent tie bars

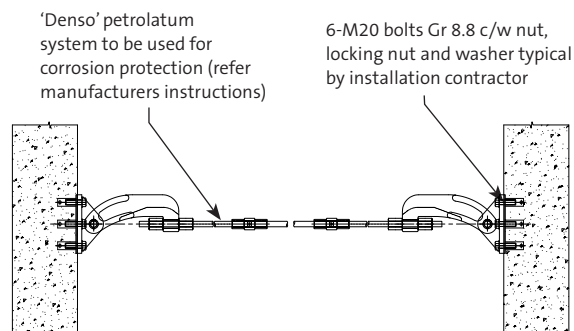

Right:
Arch to spandrel
tieback assembly
wrapped with
corrosion
protection tape

The horizontal joints between the upper and lower spandrels and the vertical centre joint between the upper spandrels are connected by use of the Type A connection detail as shown in Figure 12. Refer to the Humes project drawings for the actual number and location of the Type A connections as well as the other required permanent tieback assemblies.



Figure 12 – Typical spandrel detail

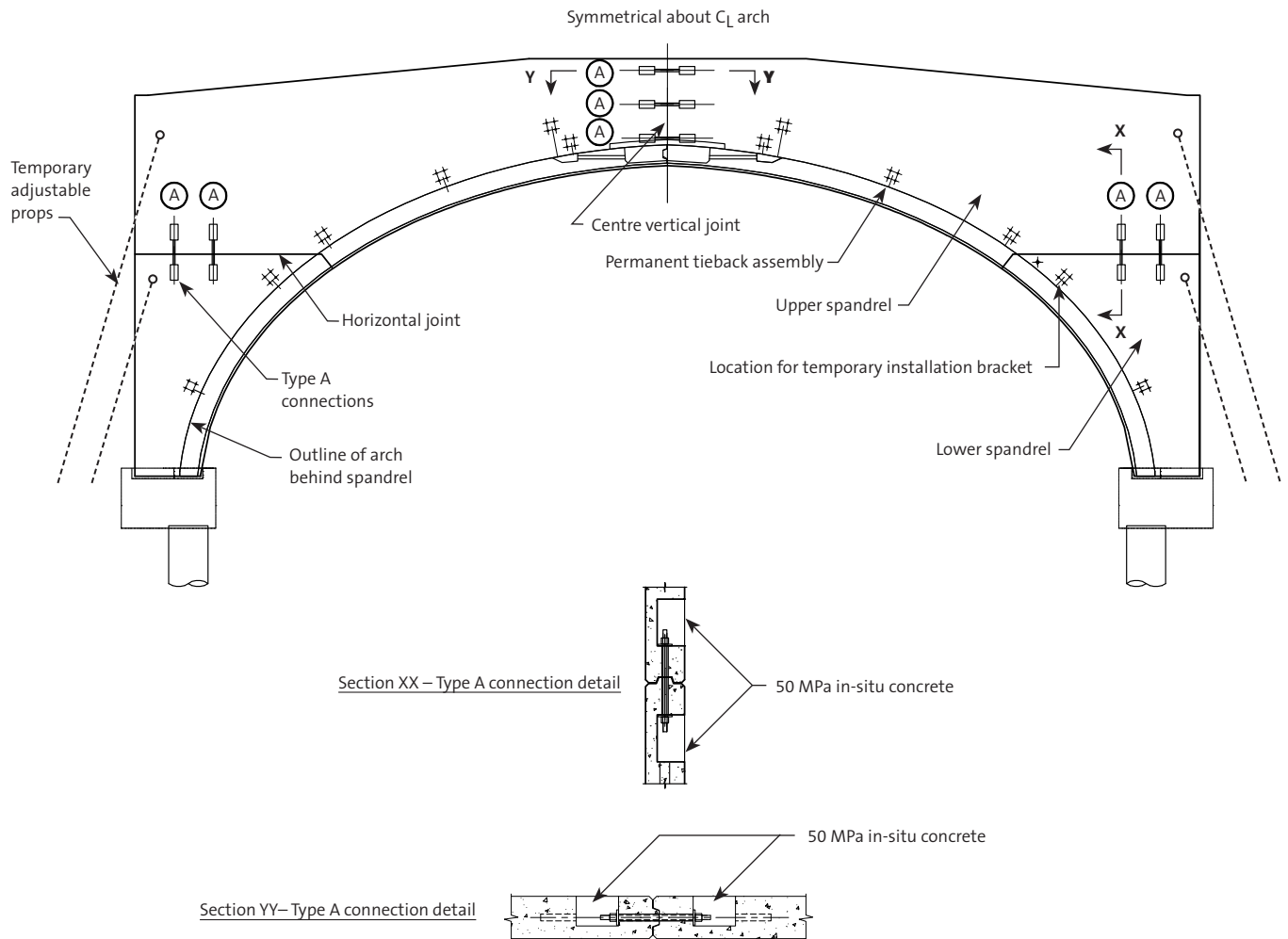

The lifting process for spandrel walls is similar to the arch element and in most cases the same lifting equipment can be used. The lifting sling configuration for the lower and upper spandrels is shown in Figures 13 and 14.

The lower spandrels sit in a rebate at the end of the arch footing which is similar to that of the arches but at right angles to arch footings with 40 mm to 50 mm clearance at the front face of spandrel and rear outer edge of spandrel (see Figure 15 below).

Erection of spandrels

1. Prior to commencing installation of spandrels, survey the ends of the arch footings in consultation with the Humes project drawings and mark the positions for installation of the lower spandrels on the footings. Install grout levelling pads or compressed fibre cement levelling pads in the footing rebate such that the underside of the lower spandrel is at the same level as the underside of the end arch unit.
2. Ensure that all the tieback assembly brackets have been bolted onto the spandrels and onto the end arch unit (or units). Also ensure that all the tie bar assemblies of one hand (either left hand or right hand threads) are attached to the arch brackets using the clevis pins and cotter pins provided.
3. Lift and rotate the first lower spandrel using the rigging as shown in Figure 13 (or refer to Humes project drawings) and position it in place in the footing rebate, keeping the crane hooked up to the lower spandrel.

Figure 13 – Rigging arrangement for lifting and erecting lower spandrels with two top edge lifters

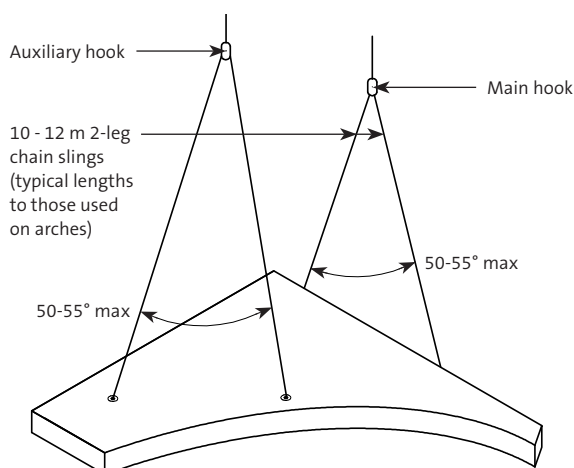

Figure 14 – Rigging arrangement for lifting and erecting upper spandrels with two top edge lifters

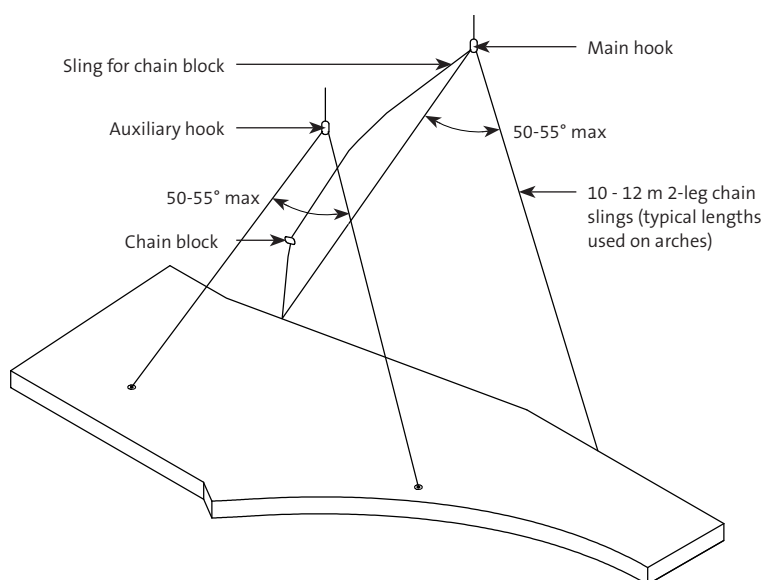
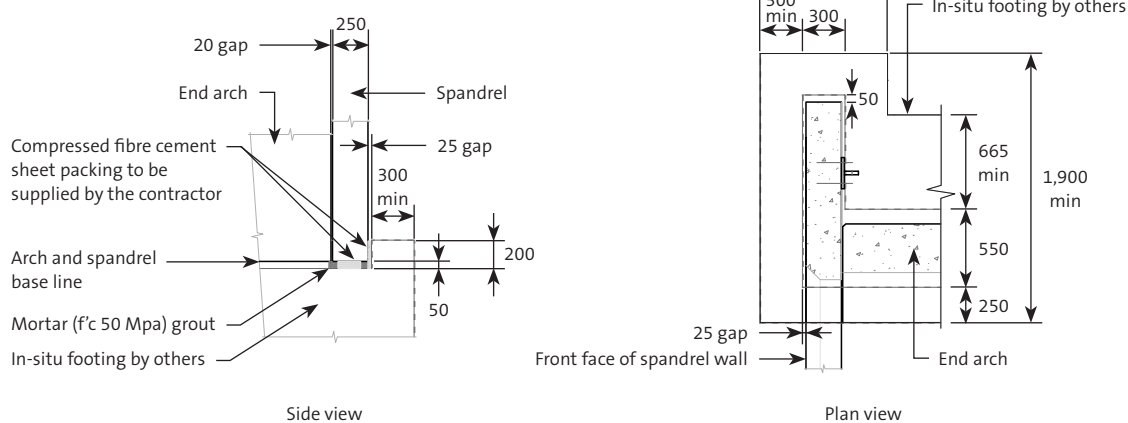

Figure 15 – Arch footing rebate detail



4. Fit the temporary installation bracket to the lower spandrel segment and pack with PVC packers (150mm x 100mm) between the temporary bracket and the arch surface to fully support the weight of the lower spandrel.
5. Complete installation of the remaining permanent tie back assemblies by connecting the tie bars to the lower spandrel brackets using the clevis pins and cotter pins provided.
6. Fit temporary adjustable props to the rear of the lower spandrel and anchor back down to the arch footing (or in accordance with the contractors propping design).
7. Use the temporary adjustable props, the temporary installation bracket and the permanent tie back assemblies for adjustment of the lower spandrel and to effectively support the lower spandrel in its final position.
8. Have a surveyor check the final position of the lower spandrel (to the survey point dimensions shown in the Humes project drawings) and then disengage the crane from the spandrel.
9. Erect the other lower spandrel on the opposite side of the arch using the same procedure outlined in steps 3 to 8 above.
10. Prior to installing the upper spandrels, insert the Type A connection tie bars through the holes in the top edges of the erected lower spandrels at the Type A connection locations. The holes extend past the bottom of the Type A connection recess such that the tie bars will not protrude above the top edge of the lower spandrels and will not interfere with subsequent installation of the upper spandrels. Similarly, insert the Type A connection tie bars through the holes in one of the upper spandrels at the vertical centre joint location so that they are flush with the centre joint face of the upper spandrel.
11. Lift and rotate the first upper spandrel using the rigging as shown in Figure 14 (or refer to Humes project drawings) and position it in place above the previously installed lower spandrel, keeping the crane hooked up to the upper spandrel.
12. Fit the temporary installation bracket to the upper spandrel segment (at the tieback position located closest to the vertical centre joint of the upper spandrel) and pack with PVC packers (150mm x 100mm) between the temporary bracket and the arch surface to fully support the weight of the upper spandrel
13. Complete the Type A connections at the horizontal joint between the upper and lower spandrels by pushing the Type A connection tie bars (previously installed in the lower spandrel) upwards through the formed holes in the upper spandrel and installing the plate washers and nuts and tightening using a suitable ring spanner.
14. Complete installation of the remaining permanent tie back assemblies by connecting the tie bars to the upper spandrel brackets using the clevis pins and cotter pins provided.
15. Fit temporary adjustable props to the rear of the upper spandrel and anchor back down to the arch footing (or in accordance with the contractors propping design).
16. Use the temporary adjustable props, the temporary installation bracket and the permanent tie back assemblies for adjustment of the upper spandrel and to effectively support the upper spandrel in its final position before disengaging the crane from the upper spandrel.
17. Erect the other upper spandrel on the opposite side of the arch using the same procedure outlined in steps 11 to 16 above but at step 13, start by completing and tightening the Type A connections at the centre vertical joint between the upper spandrels followed by completing and tightening the Type A connections at the horizontal joint between the upper and lower spandrels.

Alternate installation method

Note that the upper spandrels could also be installed by the following alternative method, replacing steps 11 to 17 on the previous page.

Both the upper spandrels are simultaneously lifted, rotated and positioned to within 100 mm to 200 mm above the lower spandrels using two separate cranes (one for each upper spandrel).

While in this position, the two upper spandrels are joined together by aligning them at the vertical centre joint and the Type A connections are completed and tightened against the fibreboard packers which are glued to the vertical joint faces of the upper spandrels in the factory.

The joined upper spandrels are then lowered simultaneously by both cranes onto the lower spandrels and aligned in position before completion and tightening of the Type A connections at the horizontal joints between the upper and lower spandrels.

Using this method, the temporary installation brackets, permanent tieback assemblies and temporary adjustable props are then installed and adjusted (as per steps 12 to 16 on previous page) before disengaging the cranes from the upper spandrels.



Left:
Upper spandrels
being joined and
lowered into
position

Erection of precast elements – Wingwalls

When excavating into an embankment for wing walls, for safety during erection of the wing walls, it is good practice that the cut be approximately 1,800 mm to 2,000 mm past the last wingwall unit.

The allowable bearing capacity of the exposed foundation needs to be checked by a suitably qualified geotechnical engineer. A foundation with minimum bearing capacity of 200 KPa working is required. Where the natural material is not a suitable foundation, once this has been confirmed it should be excavated and replaced with compacted granular material.

The use of a suitable geofabric material may assist in stabilizing the existing foundation and may be of some benefit in many situations. The depth of material and its

compaction should be determined by site investigations and recommendations of a suitably qualified geotechnical engineer.

Wingwalls require an in-situ reinforced concrete foundation slab or in-situ concrete strip footings to which the base of the precast wingwalls may need to be dowelled or bolted to prevent sliding and/or overturning of the wingwalls. The Humes project drawings will provide the relevant details in these cases.

The design and detailing of the in-situ concrete foundation slab (or strip footings) is the responsibility of the owner's design consultant, as they are responsible for confirming the overall global stability of the wingwalls.

Figure 16 – Lifting of wingwalls

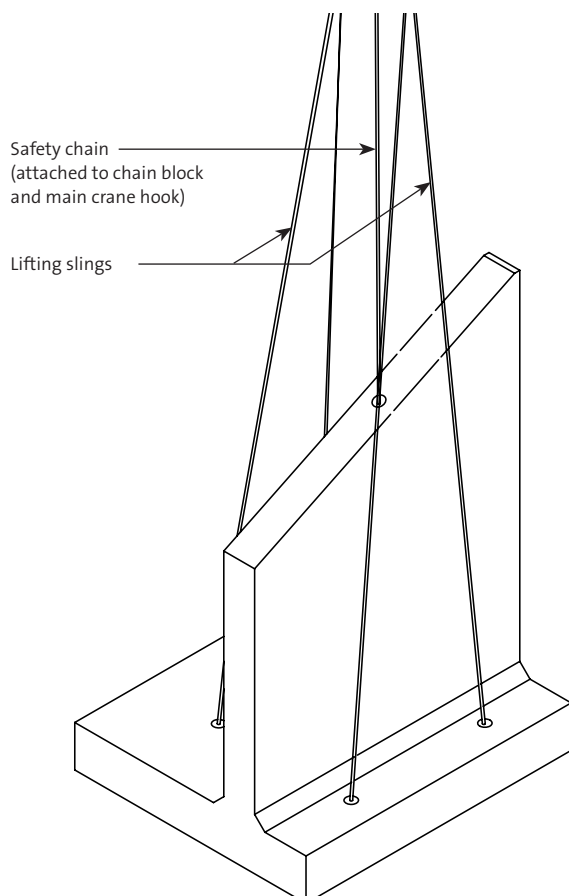

Top:
Wingwall footing
setup

Middle:
Fully installed
wingwalls

Bottom:
Lifting of heavy
duty wingwall

Prior to commencing installation of the wingwalls, set out 50mm thick levelling packers on the concrete in-situ base slab (or strip footings) corresponding to the four corners of the base of the wingwall units. The levelling packers can be compressed fibre cement sheeting, similar to those used for the arch units and levelling can be fine tuned using PVC packers as required.

The wingwalls are generally supplied in the as cast position and require rotation into the upright position for installation, although the smaller wingwalls may be delivered in the upright position (refer Figure 5).

Using both main and auxiliary crane hooks attached to the cast-in lifting anchors, the wingwalls can be lifted and rotated in the air and placed onto flat ground for re-rigging (refer Figure 16). With the wingwall in the correct orientation it can be lifted onto the prepared foundation and placed on the pre-levelled packers. In the interest of safety it is recommended that a safety sling and chain block attached to the top of the wingwall blade and back to the main hook of the crane be used for all wingwalls.

If the wingwall does not hang level, place a sling with a chain block attached off the main hook of the crane, hook onto the out of level corner lifting knuckle and adjust the wingwall to sit down flat onto the pre-levelled packers.

For assemblies with wingwalls arranged from 90° and up to 120° where the spandrel is supported by the first adjacent wingwall, the joint between the spandrel wall and the first wingwall element should be clean, smooth and uniform so as to provide an even bearing support for the spandrel wall. No mastic jointing material is required to cover this joint, however it is recommended that a 600 mm wide vertical strip of no-fines geotextile is glued to the rear of the wingwall joints to prevent loss of fines and also over the weep holes located at the bottom rear of the wingwall blade.

Once the first wingwall has been installed in position, the remaining wingwalls are placed and aligned in a similar manner.



Grouting, sealing and in-situ concrete

Grouting

After complete installation of the arches and spandrels, the keyway in the arch footings is to be filled with either:

- a) A proprietary, flowable, non or low shrinkage 50MPa grout or
- b) A flowable 50MPa concrete mix with 7 mm maximum aggregate size, which does not record more than 400 microstrain when tested in accordance with AS 1012.13.

Note that special care should be taken during placement of the grout or concrete mix in the arch footing keyway to ensure that the entire keyway is completely filled such that there are no air gaps remaining around and beneath the arches and spandrels. Where a 50MPa concrete mix is used, it must be either sufficiently flowable or adequately compacted during placement to ensure this.

After the arches, spandrels and wingwalls have been erected, the following areas should be grouted as soon as possible while they are clean and dry:

- The arch footing and spandrel keyways are to be filled over their entire length and adequately compacted to ensure they are completely filled as described above.
- The gap between the underneath side of the wingwalls and the top of the concrete base slab (or strip footings) is to be filled with a flowable grout. Note that if any dowels are required they should be installed in the dowel holes provided prior to grouting. The perimeter of the wingwall bases is normally sandbagged (or similar) and the grout poured through the nominal 100mm diameter holes in the base of wingwalls.
- All arch lifting anchor recesses, top arch tie rod recesses and spandrel Type A connection recesses are to be filled with a 50MPa dry pack mortar/grout or a 50MPa concrete mix.

Top arch in-situ joint

Top:
Top arch in-situ
joint keyway
stirrups bunched
together

Middle:
Top arch in-situ
keyway with
reinforcement
ready for concreting
(top mesh is not
included) – note
joints are taped

Bottom:
Completed top
arch keyway in-situ
joint

Once the arch footing grouting is complete and initial set has taken place, the top arch in-situ keyway joint may be commenced. Refer to the Humes project drawings for all the top arch in-situ joint reinforcement details.

Note: Before placing and fixing the reinforcement in the top arch in-situ keyway joint, all joints between the products must be sealed with jointing materials recommended in the next section of this manual, being careful not to let the primer run through the joints to the underside of the arches.

The stirrups used in the top arch in-situ keyway joint are normally bunched together and attached to the exposed reinforcement bars in each arch keyway at the Humes factory ready to be spaced over the exposed reinforcement bars and the installed splice bars as shown in the images opposite.

In practice it is generally more efficient to pour a continuous keyway the full length of the arch structure rather than separate in-situ joints for each individual arch.

After placement of the reinforcement in the keyway, in-situ concrete is placed, taking particular care to vibrate the concrete so that it penetrates to the bottom of the keyway and all around the reinforcement, thereby ensuring removal of all voids from the concrete.

Note that no placement of backfill material to the sides of the arches is to commence until both the grout in the arch footing keyway and the top arch in-situ joint concrete have been placed and achieved a minimum strength of 20MPa.

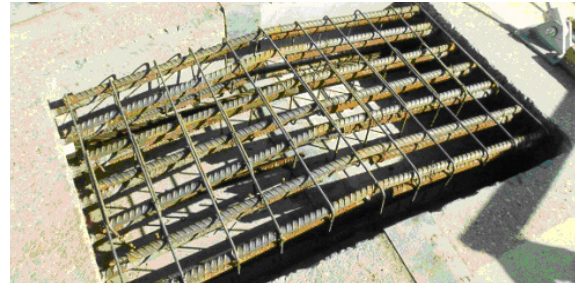

Other in-situ concrete

Depending on the application and the loading conditions, additional in-situ concrete detailing may be required.

Any additional in-situ concrete details will be provided in the Humes project drawings where required.

Sealing of joints

A backing rod and a 250 mm wide strip of adhesive mastic tape, backed on one side with a durable synthetic laminate and primed to the manufacturers specifications are used on the following areas:

- All joints between arches.
- All joints between spandrels.
- The arch to spandrel joints.

Note: Sealing of joints can be carried out progressively as the backfill is coming up. This then allows people to be working from the ground level.

It is recommended that the vertical joints between spandrel and wingwall and wingwall to wingwall should be covered with a suitable geotextile to prevent the loss of backfill fines. These joints could also be sealed using mastic tape as noted above.

The use of a general adhesive material on the concrete helps hold the geotextile in position whilst backfilling occurs.

Also note that depending on the mortar or grout filler used in the arch footing keyway, a waterproofing membrane (of similar material used to seal joints as noted above) may need to be applied across the outside face surface of the arch to keyway connection (Refer Figure 1)



Top:
Joints sealed,
checking backfill

Middle:
Sealing of arch,
spandrel and
wingwall joints

Bottom:
Detail of arch and
spandrel joint



Backfilling

General

The arch backfill specification details provided below are general in nature and may vary for specific projects. The Humes project drawings provide the project specific specification for arch backfill and take precedence.

Backfilling operations at the sides of the arch can commence when the in-situ concrete at the arch units joint at the top of the arch and the footing keyway grouting has at least 20 MPa strength (higher strengths may be required for large arches or arches designed for heavy loads). This can be confirmed by use of concrete cylinder strength testing or by allowing sufficient time after placement of concrete or grout to achieve the required strength (suggested minimum of three days).

Backfilling over the top of the arch can take place when the in-situ concrete at the top arch joint has at least 30 MPa strength.

This stage of construction represents one of the most important series of load cases experienced by the structure. Damage to the structure can result if the correct procedures are not followed. The critical zones of backfilling are as indicated in Figure 17 below.



Left:
Observe the no go zone for heavy equipment

Ensure that the no go zone for heavy construction and compaction equipment is maintained during placement and compaction of the backfill material as described under Backfill Compaction on page 30. The no go zone is defined as an area which is a minimum of 300mm from the arch surface and a minimum of 300mm from the rear of the spandrels and wingwalls.

Figure 17 – Backfill zones for specification

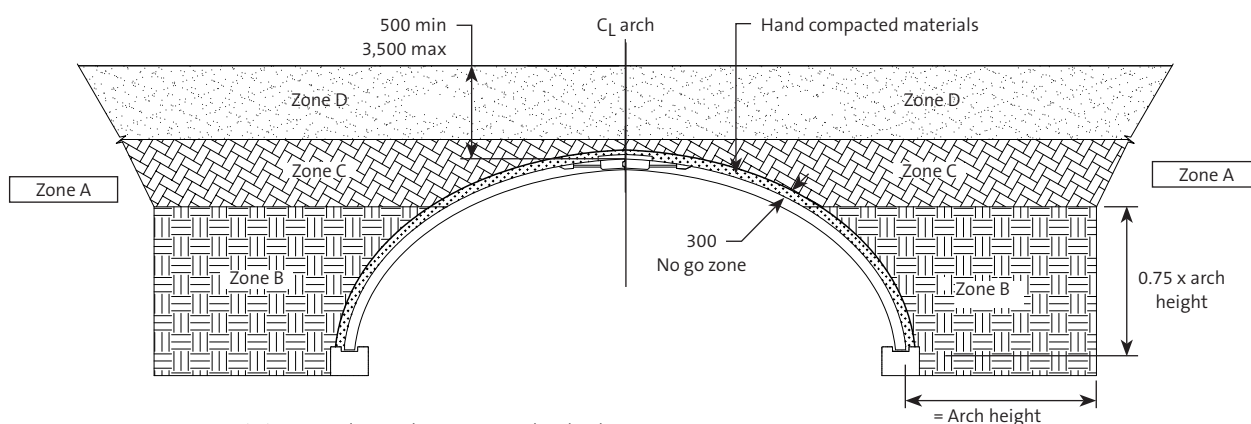

- Zone A** – Existing natural ground or constructed embankment
- Zone B** – Sidefill necessary for effective arch support
- Zone C** – Overfill providing uniform loading
- Zone D** – Road superstructure (including subgrade material and gravel, asphalt or concrete road pavement) or embankment

Backfill material specification

Zone A

The Zone A material extends beyond the limits of Zones B, C and D and can be either natural ground (existing soil) or compacted embankment fill material in accordance with the owners consulting engineers project specifications.

Where the arch structure is to be installed into excavated natural ground, in order to minimise excavation, the natural ground can extend into the specified Zone B, provided that the natural ground is sufficiently stable to allow effective support to the arch units. In addition, where the excavation is in rock, the Zone B material between the excavated rock face and the outer arch surface may need to be wrapped in a suitable geofabric material to ensure that under saturated conditions, fines are not lost and compaction is maintained.

Zone B

This is the critical zone for the soil/structure model and careful consideration of the material specification for quality and placement is absolutely essential.

The material specification extends vertically up from the in-situ footings to 75% of the arch height and extends laterally for a distance equal to the arch height beyond the surface of the arch at the level of the in-situ footing and may consist of material from one of the following soil groups:

- GW – (gravel or sandy gravel, well graded)
- SW – (sand or gravelly sand, well graded)
- GC – (clayey gravel or clayey sandy gravel)
- SC – (clayey sand or clayey gravelly sand)

Soils within the soil groups and which fall within the grading limits (shown in the table below) and with a liquid limit equal to or less than 30% and a plasticity index equal to or less than 10 are required provided that these materials, in their compacted state, exhibit an angle of internal friction of not less than 30 degrees.

Apparent gravelly materials, which become unstable and break down to become primarily silts and clays when wetted such as shalestone or naturally cemented conglomerates, are not suitable materials and must not be used.

Unsuitable natural materials may become satisfactory when blended with cement or imported materials, provided the specified compaction can be achieved. Where on site material outside of the above specification for either grading, liquid limit or plasticity index is to be considered for use as Zone B material, Humes must be advised and an experienced geotech engineer may need to be consulted.

Note that it is acceptable to use Zone B material in place of Zone C and Zone D material.

Zone B material grading limits

| Sieve size (mm) | Passing (%) |
|-----------------|-------------|
| 75 | 100 |
| 9.50 | 80 – 50 |
| 2.36 | 70 – 30 |
| 0.60 | 50 – 15 |
| 0.075 | 25 – 10 |

Figure 18 – Low level fills (recommended for overfill up to 500 mm)

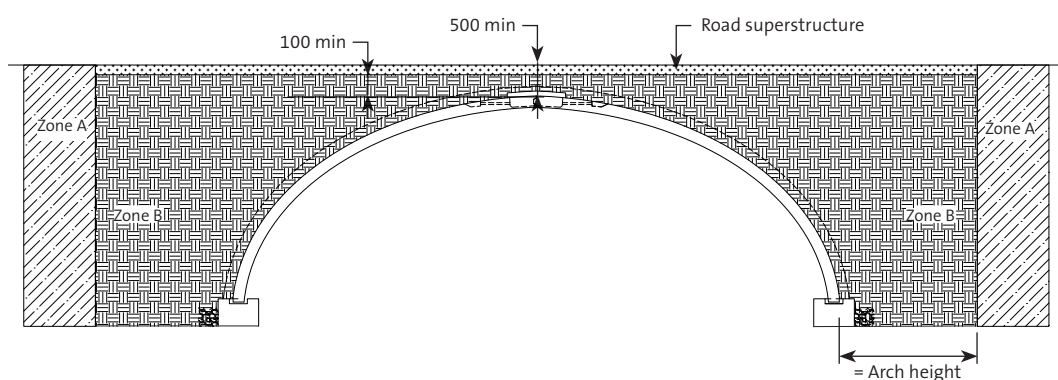

Zone C

This is the overlay material which extends up to 500 mm above the top of the arch and should be substantially free of organic matter, generally free of stones larger than 150 mm and free of stones larger than 75 mm within 300 mm of concrete surfaces (i.e. arches, spandrels and wingwalls). The material should also have good compaction properties and be easily compacted and stable in place.

Zone D

The road superstructure (including subgrade material and road pavement) or embankment according to the owners consulting engineers project documents.

For low level fill applications where the road pavement (gravel, asphalt or concrete) falls within the Zone C material, then Zone B must extend up to a minimum level of 100 mm above the top of the arch surface prior to placement of the road subgrade material and Zone C material is not used (refer to Figure 18).

Figure 19 – Dumping of backfill

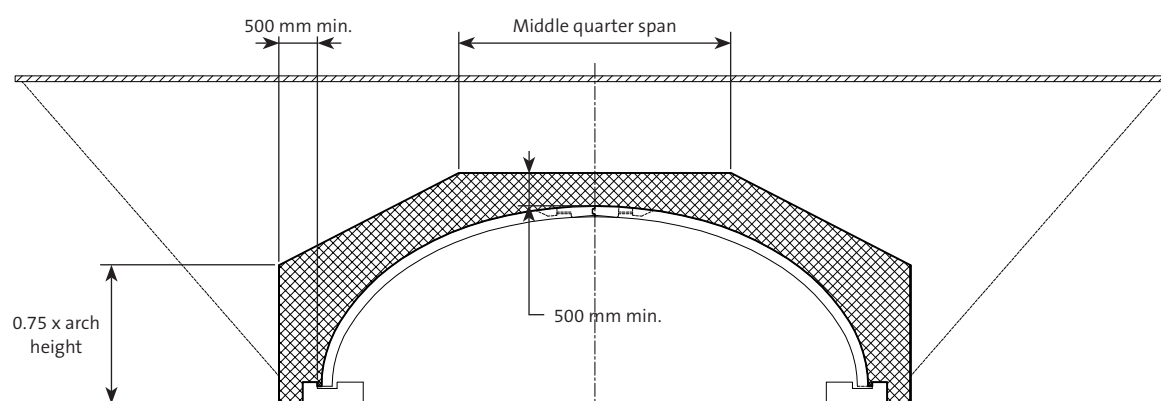

Embedment materials placement

Top:
Backfill levels
marked on spandrel

Bottom:
Backfill levels
marked on arches

The sidefill and overlay material should be placed in loose layers not exceeding 300 mm so as to achieve the required compaction. Dumping of backfill material is not allowed adjacent to and within the middle quarter of the arch until the height of fill over the arch exceeds 500 mm (refer to Figure 19).

The most critical factor during backfilling is that the maximum difference in the levels of compacted fill on opposite sides must not exceed 600 mm in Zone B. This difference must alternate from side to side as the fill rises up the arch sides so that the backfill operation induces no permanent sideways movement in the arch.

Lines may be marked on arch units and spandrel indicating each fill level as a guide to the equipment operators and to help ensure that the maximum difference is not exceeded.

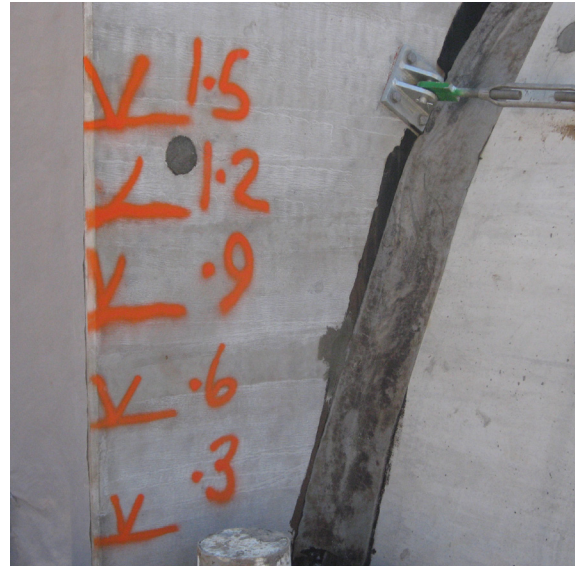
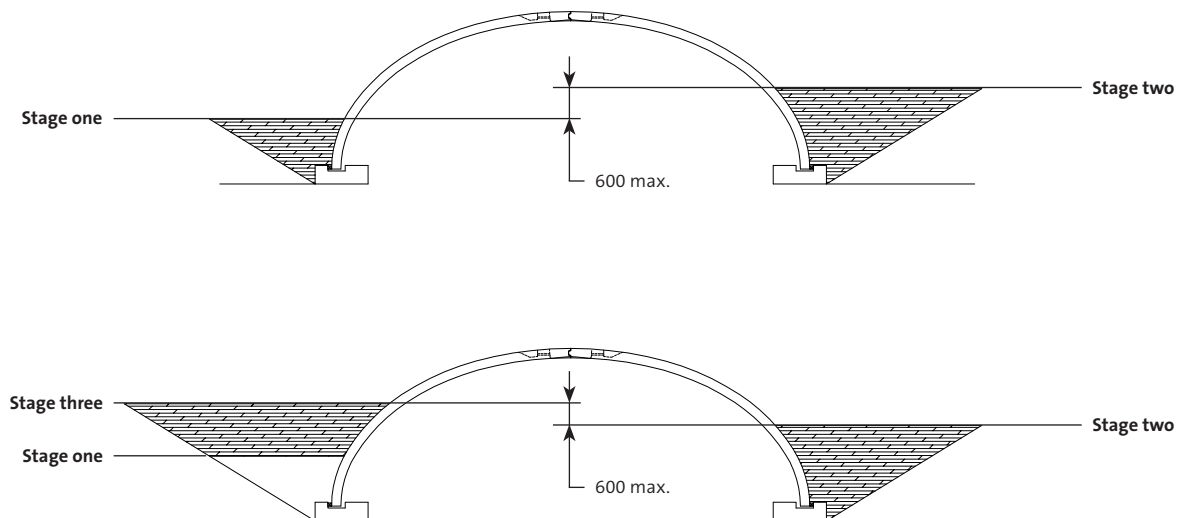

Figure 20 – Zone B backfill stages



Backfill compaction

Zone B (sidefill) backfill material must be compacted to not less than 95% of the maximum dry density at optimum moisture content for standard compaction.

Zone C (overlay) and Zone D backfill material shall be compacted in accordance with the owner’s consulting engineer’s project specifications for compacted embankment fill.

To avoid damaging or causing instability of the structure, the backfill material adjacent to the arch and behind the wingwalls and spandrels is hand compacted as shown in Figure 21 below.



Left:
Hand compaction
of backfill

Figure 21 – Hand compaction zones

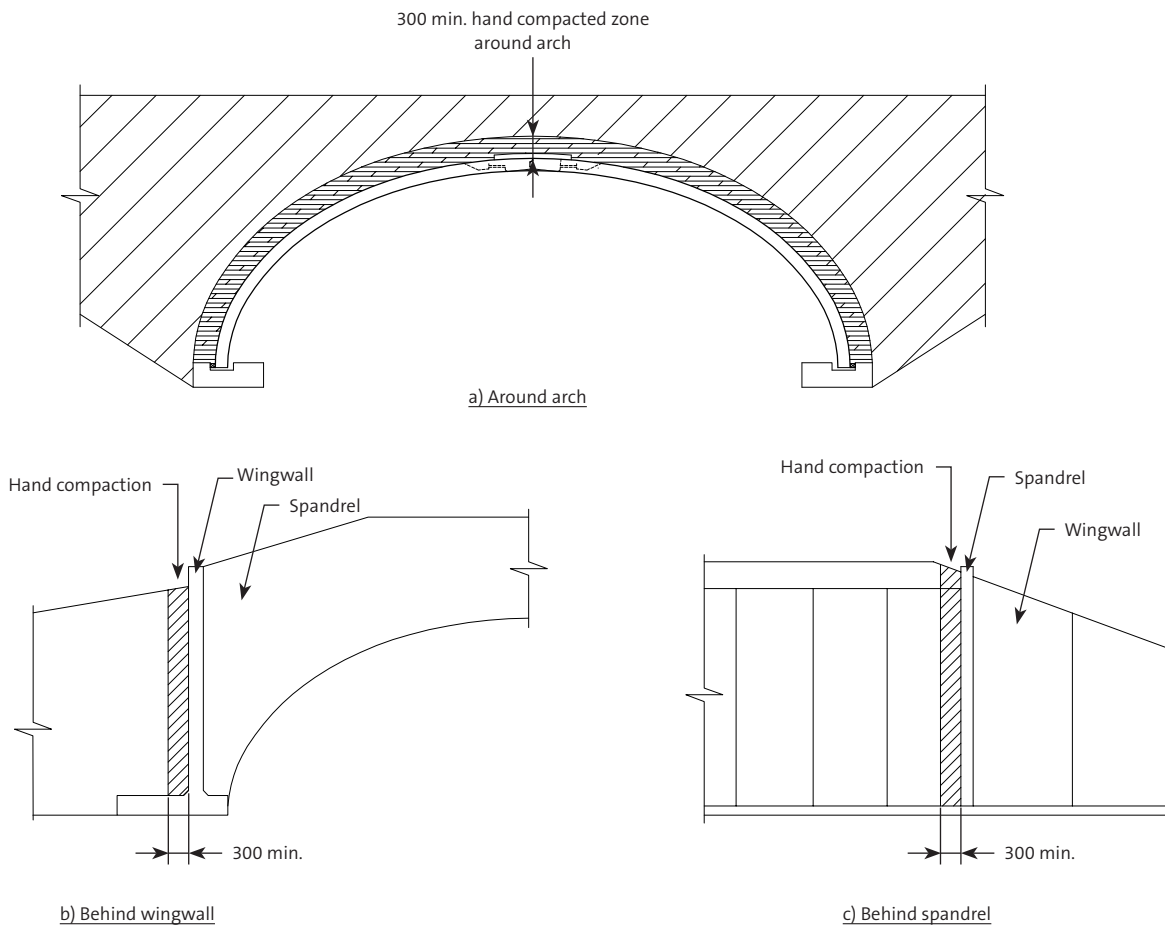

Restrictions for construction machinery

For the immediate area of the arch, there are restrictions for construction machinery as follows:

- a) The bare arch may not be crossed over by any heavy construction equipment.
- b) Construction and compaction equipment heavier than 10 tonnes is not allowed in the backfill zone indicated in Figure 22.
- c) To avoid excessive vibration in the arch, heavy vibrating compaction equipment (greater than 5 tonne) should be started and switched off outside the limits as shown for dumping in Figure 19.
- d) After compacted fill has been placed to a height of 500 mm over the crown, construction equipment with a maximum gross vehicle weight of 30 tonnes may cross the arch. If construction equipment with gross vehicle weight greater than 30 tonnes is required to pass over the arch, consult Humes engineers to confirm if this is possible and the minimum fill height which may be required over the top of the arch.

Figure 22 – Construction equipment limits

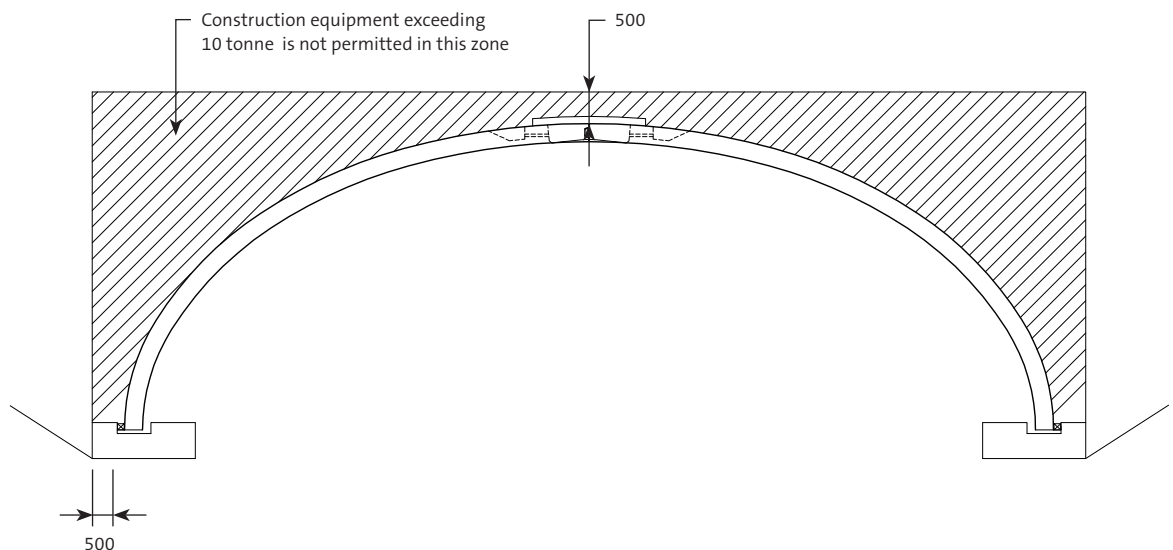

Appendices

1. Two piece arch profiles
2. Sample shopping list
3. Pre-erection checksheet
4. Shim block configuration and installation process

Appendix 1 – Two piece arch profiles

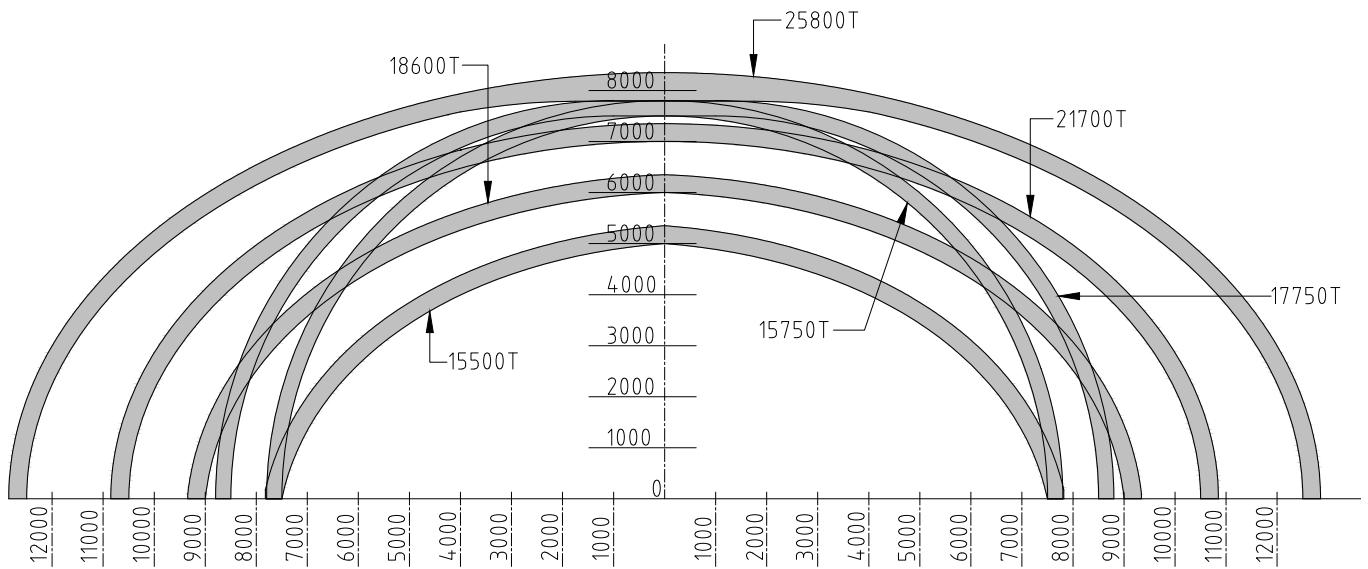

Arch dimensions

| Arch profile | Span | Height | Thickness |
|--------------|-------|--------|-----------|
| 15500T | 15000 | 5000 | 350 |
| 18600T | 18000 | 6000 | 350 |
| 21700T | 21000 | 7000 | 350 |
| 15750T | 15000 | 7500 | 300 |
| 17750T | 17000 | 7500 | 300 |

Appendix 2 – Sample two piece arch installation shopping list

Date:.....

Project:.....

Two piece arch structure comprising of:

..... off half arch units in total, including specials, weighing approx. tonnes each.

..... off S..... RH spandrels weighing approx.tonnes each.

..... off S..... LH spandrels weighing approx.tonnes each.

..... off S..... RH spandrels weighing approx.tonnes each.

..... off S..... LH spandrels weighing approx.tonnes each.

..... off W..... wingwall weighing approx.tonnes each.

..... off W..... wingwall weighing approx.tonnes each.

..... off W..... wingwall weighing approx.tonnes each.

..... off W.....wingwall weighing approx tonnes each.

| Requirements | Action |
|--|--------------------------|
| Site access suitable for trucks and cranes. | Contractor |
| Craneage to be capable of handling arches, spandrels and wingwalls from the trucks, turning them in the air and erecting them in their nominated positions. | Contractor/Crane company |
| First truck delivery of arches to have off arch tie bolts. | Humes |
| Specials sequence and quantities to be programmed into deliveries to suit erection. | Contractor/Humes |
| The Spandrels to be delivered and erected directly off the trucks. | Contractor/Humes |
| A Humes Two Piece Arches Installation Guide on site. | Contractor/Humes |
| Arch shim blocks – off for project. | Humes |
| Unilift locking klaw lifting clutches and appropriate lifting equipment e.g. running snatch blocks for erecting arches (four off) sling lengths for erection of Arch – Long slings mm (including snatch blocks), short slings mm, and for unloading arches – Sling lengths 10,000 - 11,000 mm. | Contractor/Crane company |
| <ul style="list-style-type: none"> • Snatch slings to be minimum of 8,000 mm long overall. • Unilift locking klaw lifting clutches required: <ul style="list-style-type: none"> off 20 tonne off 10 tonne off 5 tonne | |
| Safety harnesses will be required to access the top of the arches (three off) | Contractor/Crane company |
| Arch leveling packers set under arches in lieu of concrete pads, packer size is 400 mm x 300 mm to make up packer height of 50 mm using 19 mm and 12 mm compressed sheeting cut to the nominated sizes - a total of 98 off sets x 50 mm high required. | Customer |

| Requirements | Action |
|--|----------------------------------|
| <p>Miscellaneous plastic packers required for erection are 150 mm x 100 mm of varying thickness, 2 mm, 5 mm, 10 mm and 20 mm available off the shelf. Number required depends on the accuracy of the footings.</p> <p>Initial requirement – off packs 2 mm, off packs 5 mm (one pack = 100), off 50 x pack 10 mm, off 50 x pack 20 mm</p> | Contractor |
| <p>Supply off softwood wedges 200 mm long x 75 mm wide x 50 mm thick tapering down to 20 mm. These are used to hold arch bases back against shim blocks during final positioning.</p> | Contractor |
| <p>Supply off T spacers 150 mm x 50 mm on top and tapering 30 mm thick at the top to 15 mm at the bottom. These are used to maintain arch joint width at the top of the arch.</p> | Contractor |
| <p>Arch “joint centre lines” to be marked on top of rear face on both sides of arch footings (see Appendix 3 - Pre-erection checksheet).</p> | Contractor |
| <ul style="list-style-type: none"> • On day one erection a surveyor is required to check initial erection of arches and at progressive stages, e.g. every five to seven arches, to prevent creep on footings. • Whilst erecting spandrel and wing walls a surveyor is required to mark and check spandrel survey points and dimensions as required. | Contractor |
| <p>Arch tie bolts – two per unit for the first two spans – lightly tensioned, then one per span with every second rod removed and reused.</p> <p>Note: At the completion of each day’s erection the last two full arch units (one at each end of the structure) will have two rods each and lightly tensioned. The final two full arches (one at each end of the bridge) must also have two rods lightly tensioned and left in the bridge. Alternatively, if shown on the project drawings, two arch tie bolts may be required for each full arch and left permanently in the bridge.</p> <p>Total rods required off</p> | Contractor |
| <p>..... off stepladders required on site to access lifting knuckles when unloading and unhooking arches.</p> | Contractor |
| <p>Five off birk bars for adjusting units during erection (two off on each side and one off on top of arches).</p> | Crane company |
| <p>Leveling of packers and set out of job prior to erection (see Apdx 3-Pre-erection checksheet).</p> | Contractor |
| <p>Two off come-alongs (1-2 tonne) complete with suitable soft slings normally carried by cranes. Used for pulling top arch joints together and/or to level and adjust units as required.</p> | Contractor/Crane company |
| <p>Two off 3 tonne chain blocks complete with suitable length slings normally carried by cranes, used for leveling spandrels and wing walls.</p> | Contractor/Crane company |
| <p>Primer and mastic to be supplied and installed by the contractor as per the manufacturers specifications.</p> | Contractor to supply and install |
| <p>All alignment of arches to be carried out by Theodolite or stringline and plumb bob.</p> | Contractor |
| <p>Checking of footings for both parallel and critical width with shim blocks supplied by Humes. Appendix 3 is to be completed by on site surveyor.</p> | Contractor |
| <p>Necessary hand tools are required to adjust and tighten arch to spandrel tieback brackets (e.g. two off ring spanners to suit M20 nuts) plus two off pogeey bars to tighten/loosen arch to spandrel turnbuckles and one pair of pliers for turnbuckle bracket clevis split pins.</p> <p>Two ring spanners to suit arch to arch tie bolts.</p> | Contractor |
| <p>Fitting of spandrel and end arch tie back fittings to be carried out prior to delivery of these units to site.</p> <p>Note: The spandrel turnbuckles fittings located where the spandrel temporary erection bracket is positioned are to be fitted loose only as they are removed for erection.</p> | Humes |

| Requirements | Action |
|--|---------------|
| Tail ropes will be required for all units during erection | Crane company |
| All Arch, Spandrel and Wingwall unit lifting points to be checked with lifting clutches before units leave factory. | Humes |
| Mesh required for on site cast in-situ key at the top of arch. | Contractor |
| All top arch keyway jointing reinforcement, stirrups etc. to be supplied and attached to each joining arch prior to delivery to site. | Humes |
| All lifting recesses and arch tie bolt recesses to be patched/filled with concrete on completion of erection, as shown on Humes drawings. | Contractor |
| It is recommended that all footings' set-out and set up be checked as per "Appendix 4 - Shim Block Configuration and Installation Process" prior to erection day. | Contractor |
| A scissor lift will be required on erection days for access to top of arches and spandrels. | Contractor |
| Tilt up panel acro props for spandrel to footing temporary erection support (see Figure 6.3): <ul style="list-style-type: none"> • 2 off for S...Spandrels • 2 off for S... Spandrels Check that ACRO Prop end attachments are compatible with the cast in ferrules in the rear of the spandrels (see Humes Spandrel Details). | Contractor |

Notes

.....

.....

.....

.....

.....

.....

.....

.....

.....

.....

.....

.....

.....

.....

.....

.....

.....

.....

Appendix 3 – Pre-erection checksheet

| ISSUE | DATE | DWN | CKD |
|-------|----------|-----|-----|
| D | 30-01-08 | RM | DFW |
| E | 20-06-08 | RM | DFW |
| F | 04-03-09 | ALM | FA |

| DETAILS OF ALTERATIONS | |
|------------------------|--|
| GENERAL REVISIONS | |
| GENERAL REVISIONS | |
| GENERAL REVISIONS | |

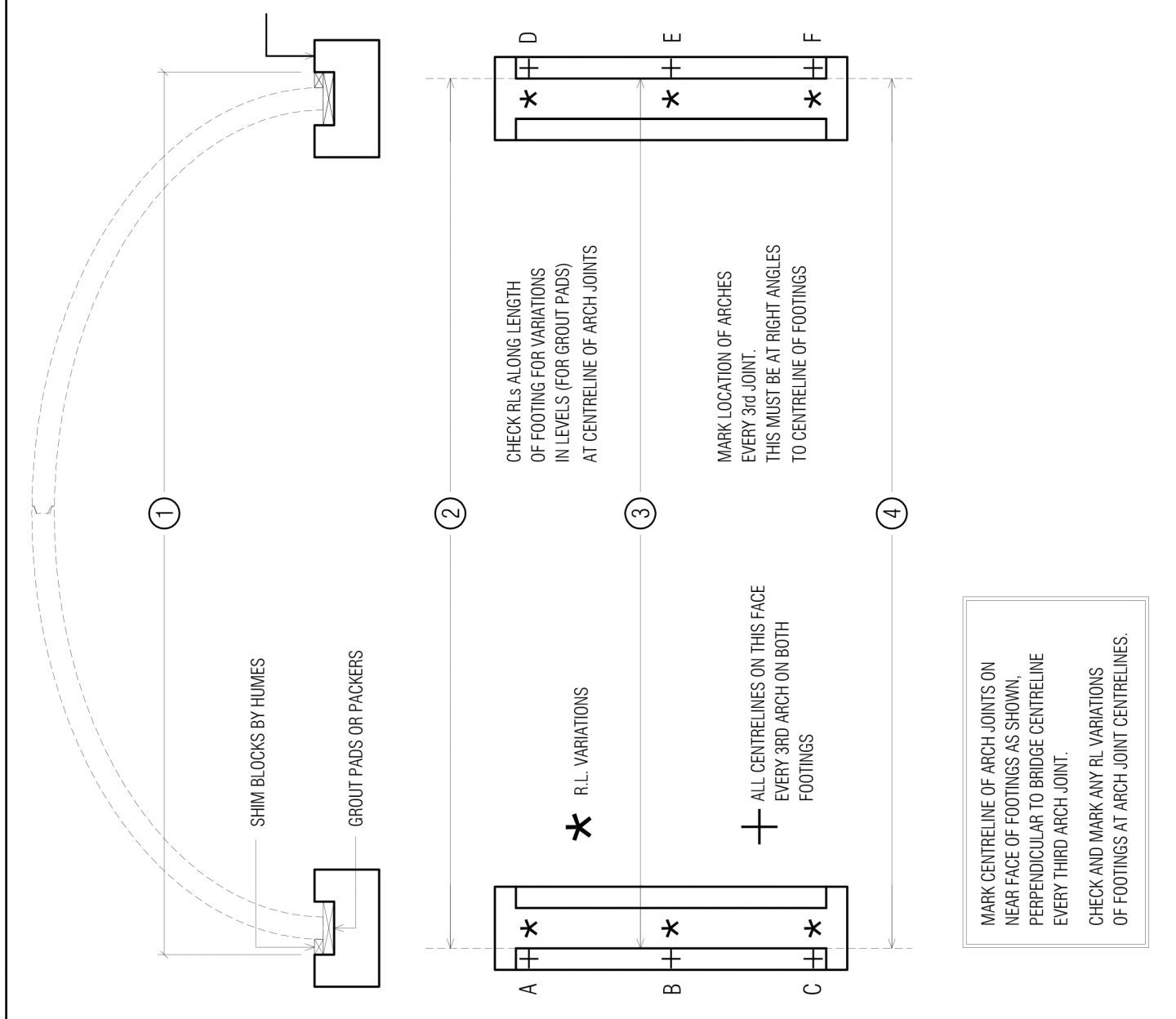

- ① THEORETICAL CRITICAL DIMENSION
- ② ACTUAL DIMENSION FAR END
- ③ ACTUAL DIMENSION MID POINT
- ④ ACTUAL DIMENSION NEAR END
- ⑤ RL VARIATIONS:

| | |
|---|---|
| A | D |
| B | E |
| C | F |

TECHNICAL (DESIGN) SERVICES
BRISBANE, QUEENSLAND

| | | | | | | |
|----------------------------------|----|----------|---|------|----------|-------|
| DSN | RM | 30-01-08 | HUMES CLASSIC TWO PIECE ARCH SYSTEM PRE-ERECTION CHECKSHEET CRITICAL DIMENSIONAL REQUIREMENTS | | | |
| DWN | RM | 30-01-08 | | | | |
| CKD | RM | 30-01-08 | | | | |
| APP | RM | 30-01-08 | | | | |
| SUPERSEDES CHK-SHT-01 Issue C | | | PLOT SCALE | SIZE | DRG. NO. | ISSUE |
| | | | 1:1 | A4 | CHK-SHT | F |

MARK CENTRELINE OF ARCH JOINTS ON NEAR FACE OF FOOTINGS AS SHOWN, PERPENDICULAR TO BRIDGE CENTRELINE EVERY THIRD ARCH JOINT.
CHECK AND MARK ANY RL VARIATIONS OF FOOTINGS AT ARCH JOINT CENTRELINES.

Appendix 4 – Shim block configuration and installation process

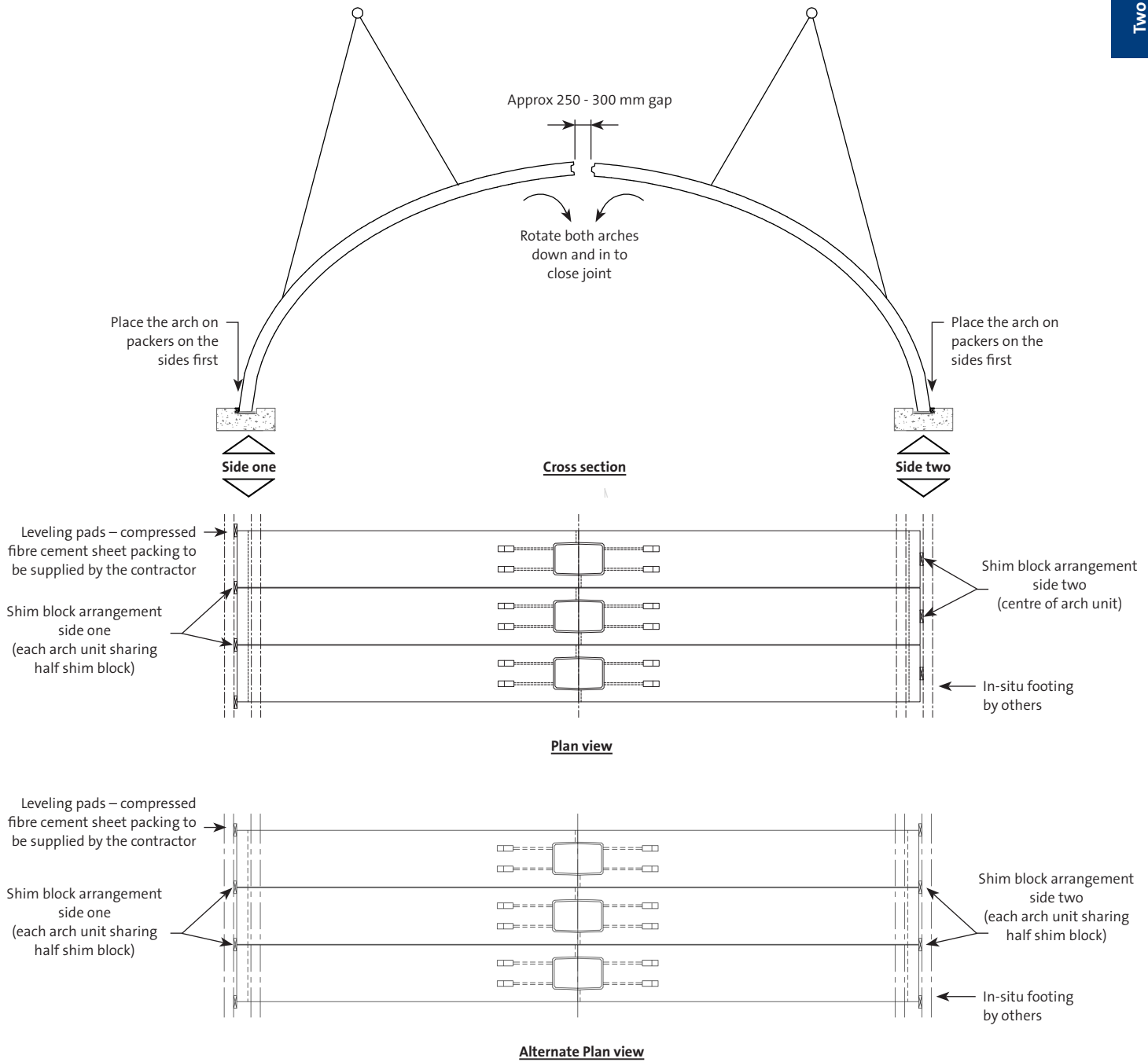

Contact information

National sales 1300 361 601

humes.com.au

info@humes.com.au

Head Office

18 Little Cribb St
Milton QLD 4064
Ph: (07) 3364 2800
Fax: (07) 3364 2963

Queensland

Brisbane/Gold Coast

Ph: (07) 3866 7100
Fax: (07) 3866 7101

Rockhampton

Ph: (07) 4924 7900
Fax: (07) 4924 7901

Townsville

Ph: (07) 4758 6000
Fax: (07) 4758 6001

New South Wales

Newcastle

Ph: (02) 4032 6800
Fax: (02) 4032 6822

Sydney

Ph: (02) 9832 5555
Fax: (02) 9625 5200

Tamworth

Ph: (02) 6763 7300
Fax: (02) 6763 7301

Victoria

Echuca

Ph: (03) 5480 2371
Fax: (03) 5482 3090

Melbourne

Ph: (03) 9360 3888
Fax: (03) 9360 3887

South Australia

Adelaide

Ph: (08) 8168 4544
Fax: (08) 8168 4549

Western Australia

Perth

Ph: (08) 9351 6999
Fax: (08) 9351 6977

Northern Territory

Darwin

Ph: (08) 8984 1600
Fax: (08) 8984 1614



National sales 1300 361 601

humes.com.au

info@humes.com.au

A Division of Holcim Australia

This brochure supersedes all previous literature on this subject. As the specifications and details contained in this publication may change please check with Humes Customer Service for confirmation of current issue. This document is provided for information only. Users are advised to make their own determination as to the suitability of this information for their own specific circumstances. We accept no responsibility for any loss or damage resulting from any person acting on this information. Humes is a registered trademark and a registered business name of Holcim (Australia) Pty Ltd. Swiftlift is a registered trademark of ITW Construction Products Australia Pty Ltd.
© January 2022 Holcim (Australia) Pty Ltd ABN 87 099 732 297